

SPECIFICATIONS:

- MODEL NUMBER:** 8025-213-256
- PUMP DESIGN:** Positive Displacement 3 Chamber Diaphragm Pump
- CHECK VALVE:** (1-Way Operation) Prevents Reverse Flow
- CAM:** 3.0 Degree
- MOTOR:** Permanent Magnet, P/N 11-194-01, Thermally Protected
- VOLTAGE:** 115 VAC Nominal
- PRESSURE SWITCH:** Adjustable Shut-Off (Range 40-60 PSI)
 Factory Set @ 60 PSI, Turn On 47 PSI ± 6 PSI
- LIQUID TEMPERATURE:** 170 Degrees Fahrenheit (77 Degrees Centigrade) Max.
- PRIME:** Self-Priming Up To 10.0 Ft. Vertical,
 Max. Inlet Pressure 30 PSI (2.1 Bar)
- PORTS:** 3/8"-18 NPT Female
- MATERIAL OF CONSTRUCTION:**
 - PLASTICS-** Polypropylene
 - VALVES-** EPDM
 - DIAPHRAGM-** Santoprene
 - FASTENERS-** Zinc Plated Steel
- NET WEIGHT:** 4.34 Lbs (1.97 Kg)
- DUTY CYCLE:** Intermittent (See Temperature Rise Chart)
- APPROVALS:** NSF/UL/CSA Listed
- BYPASS:** 45 PSI
- TYPICAL APPLICATIONS:** Water Delivery

DIMENSIONS:

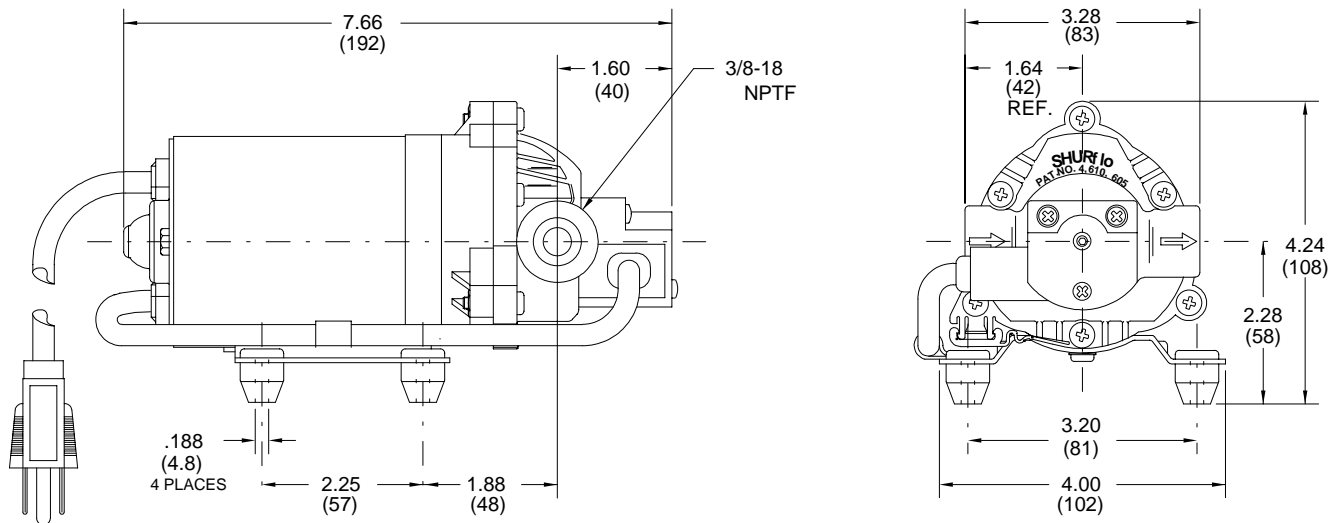

TEMPERATURE RISE

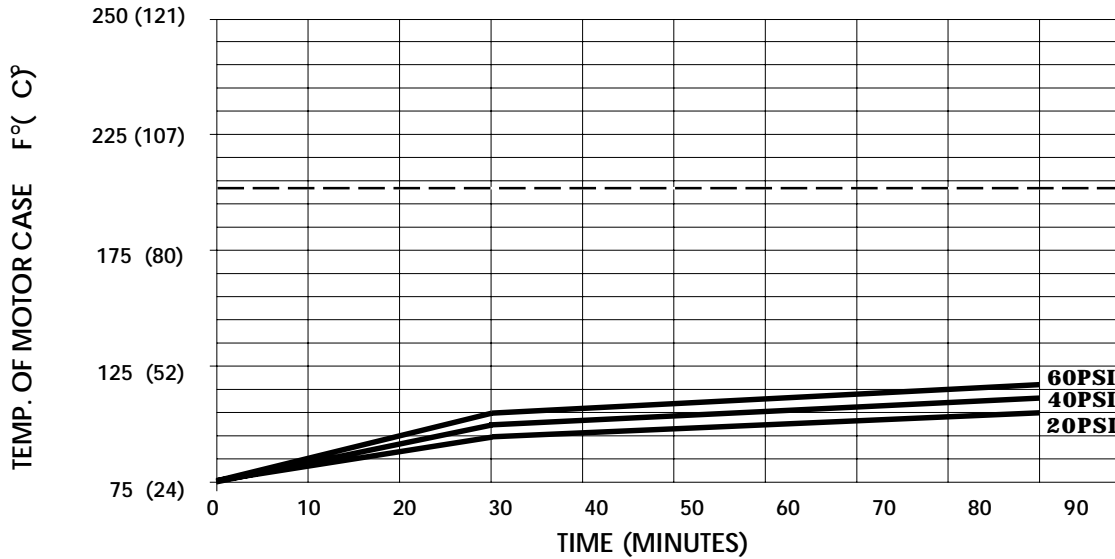

THIS GRAPH IS FOR USE AS A DESIGN GUIDE. IT IS BASED ON RUNNING CONTINUOUSLY WITH AN AMBIENT TEMPERATURE OF 75°F IN STILL AIR. THE THERMAL BREAKER WILL OPEN WHEN THE CASE TEMPERATURE REACHES 203° F.

[- - - - - TRIP POINT OF THERMAL PROTECTOR]

TYPICAL PERFORMANCE

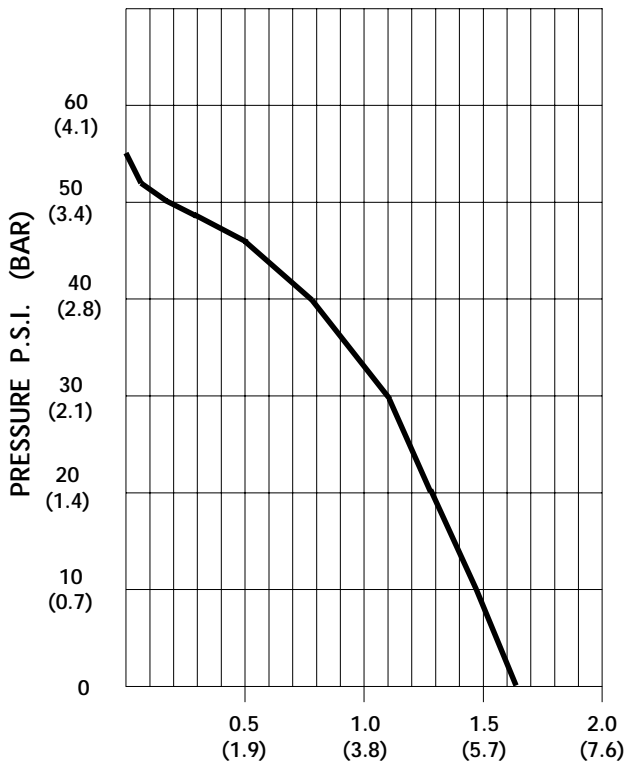

PRESSURE (PSI)	FLOW (GPM/LIT)	RPM MIN/MAX	CURRENT (AMPS)	VOLTAGE (VOLTS)
OPEN	1.62/6.1	2050/2060	0.35	115VAC
10	1.47/5.6	1980/1990	0.41	"
20	1.32/5.0	1855/1870	0.47	"
30	1.12/4.2	1735/1750	0.53	"
40	0.77/2.9	1635/1670	0.58	"
50	0.14/0.5	1580/1625	0.61	"

-SPECIFICATIONS SUBJECT TO CHANGE WITHOUT NOTICE.

-ALL DATA BASED ON TESTING WITH WATER AT AMBIENT TEMPERATURE.