

HARMSCO® Filtration Products BC6 Series

INSTALLATION AND OPERATION MANUAL

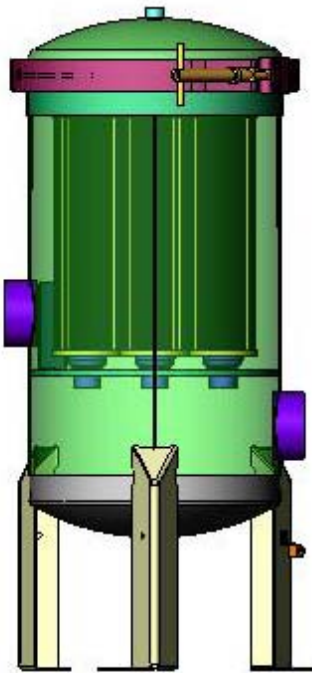

Model BC6-1

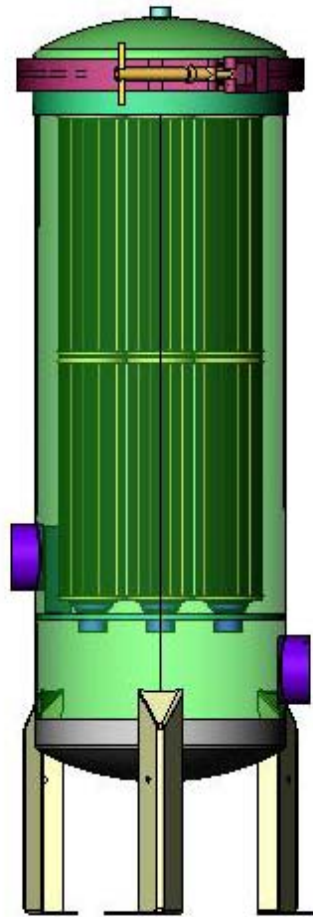

Model BC6-2

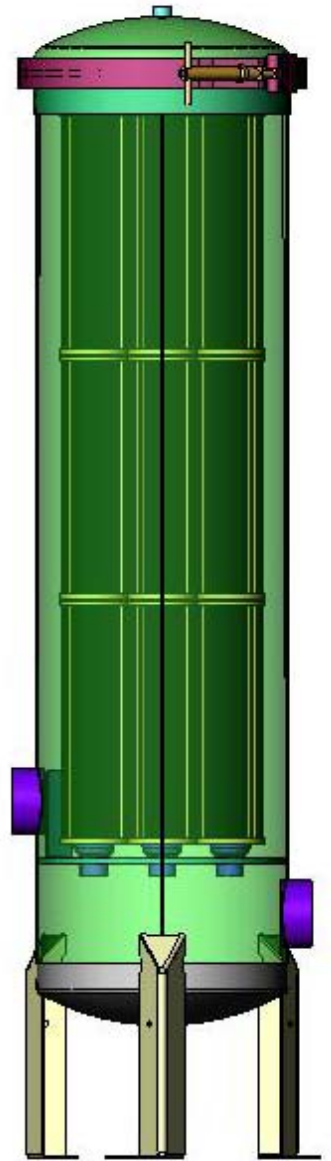

Model BC6-3

HARMSCO® Filtration Products

BC6 Series INSTALLATION AND OPERATION MANUAL

Safety Precautions:

Before using and installing the parts of this product, please read this entire manual. Failure to do so could result in serious personal injury or damage to the equipment or assembled components.

This product, and all of its components, MUST NOT be installed or used in any manner other than that which is specified in this manual.

! WARNINGS !

- 1. Do not install the unit in direct sunlight or near a heat source.**
- 2. Do not install the unit where a temperature of 35° F, or lower, can occur. Damage caused by freezing shall void all warranties.**
- 3. The unit is to be properly grounded utilizing a grounding lug located on one of the legs.**
- 4. Seek qualified assistance for installation.**
- 5. Do not backwash.**

This product is manufactured under one or more of the following patents: U.S. NO. 4,187,179; 3,720,322; CANADA NO. 977,693; GT. BRIT. NO. 1,372,014; W. GERMANY NO. 2,261,817; FRANCE NO. 7,246,864; EUROPEAN NO. 0,191,844, Other patents pending

HARMSCO® Filtration Products
BC6 Series INSTALLATION AND OPERATION MANUAL

CONTENTS

Safety Precautions & Warnings	Pg. 2
Table of Contents	Pg. 3
Recommendations	Pg. 3
Installation/Set-up	Pg. 4
Installation Block Diagram	Pg. 5
Installation Diagrams (BC6-1, BC6-2, BC6-3)	Pgs. 6, 7, & 8
Parts Diagram	Pg. 9
Operation	Pg. 10
Description	Pgs. 10 & 11
Cartridge Replacement Instructions	Pgs. 12—15
Data Specification Sheet	Pg. 16
Flow Curve	Pg. 17
Filter Cartridge Maintenance Instruction Sheet	Pg. 18
Warranty Information	Pg. 19

RECOMMENDATIONS

Installation:

Include a by-pass line for inlet and outlet with valves to isolate unit while servicing. Plumb drains with appropriate valves to reduce service time and use stainless steel fittings.

Cartridge:

Replace cartridges when necessary based on water quality, or every six months, whichever comes first.

HARMSCO® Filtration Products

BC6 Series INSTALLATION AND OPERATION MANUAL

INSTALLATION

The following diagrams show the Harmsco BC6 Housings with typical plumbing hook-up requirements.

Note: Do not install the unit in direct sunlight.
Do not install near a heat source.

1. Install incoming water supply to 2" FNPT coupling marked "Inlet".
2. Install outlet line to 2" FNPT coupling marked "Outlet", use stainless steel fitting.
3. Install valves in drain lines and connect to 1/2" FNPT couplings located at the bottom center and side of housing. Use stainless steel fittings.

Note: It is recommended to plumb a by-pass line to supply unfiltered water while servicing if necessary.

4. Mount and secure housing using the three slots at the bottom of the legs. See Installation Diagrams.
5. A qualified technician should make all connections.
6. Ground the filter housing utilizing the grounding lug on the leg.
7. Make sure housing's cartridges, lid and clamp-band are properly positioned, see the Filter Cartridge Maintenance Instructions.
8. Start the flow of water and allow the housing to completely fill.

The Harmsco BC6 Water Filter is now operational.

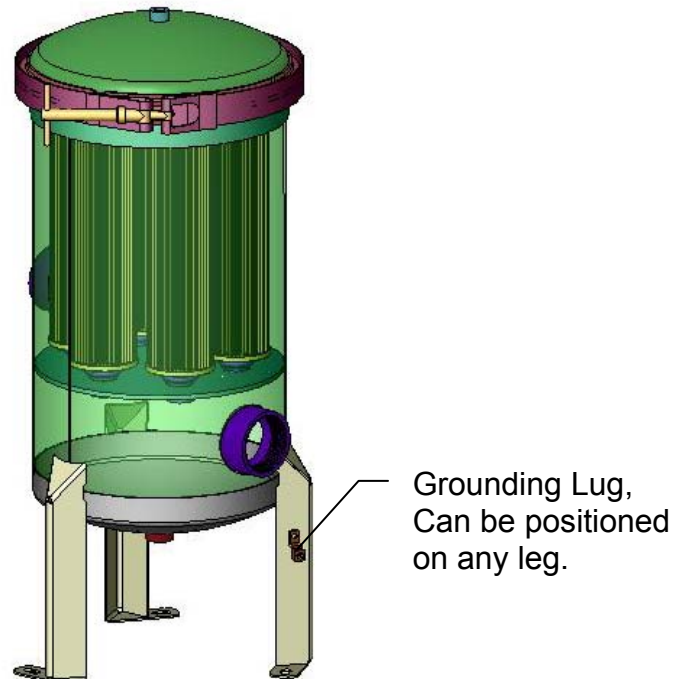

HARMSCO® Filtration Products

BC6 Series INSTALLATION AND OPERATION MANUAL

Installation Block Diagram

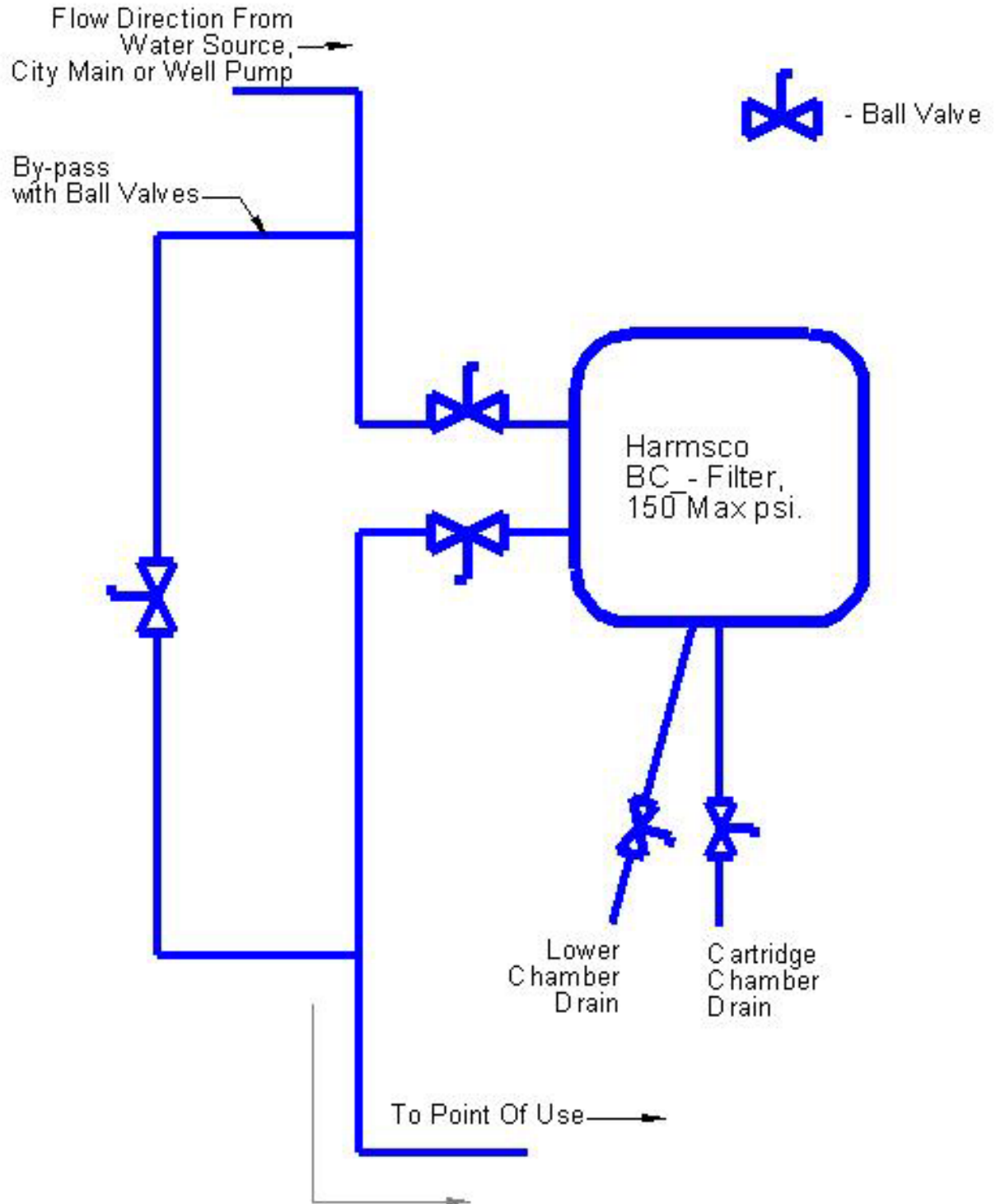

HARMSCO® Filtration Products

BC6 Series INSTALLATION AND OPERATION MANUAL

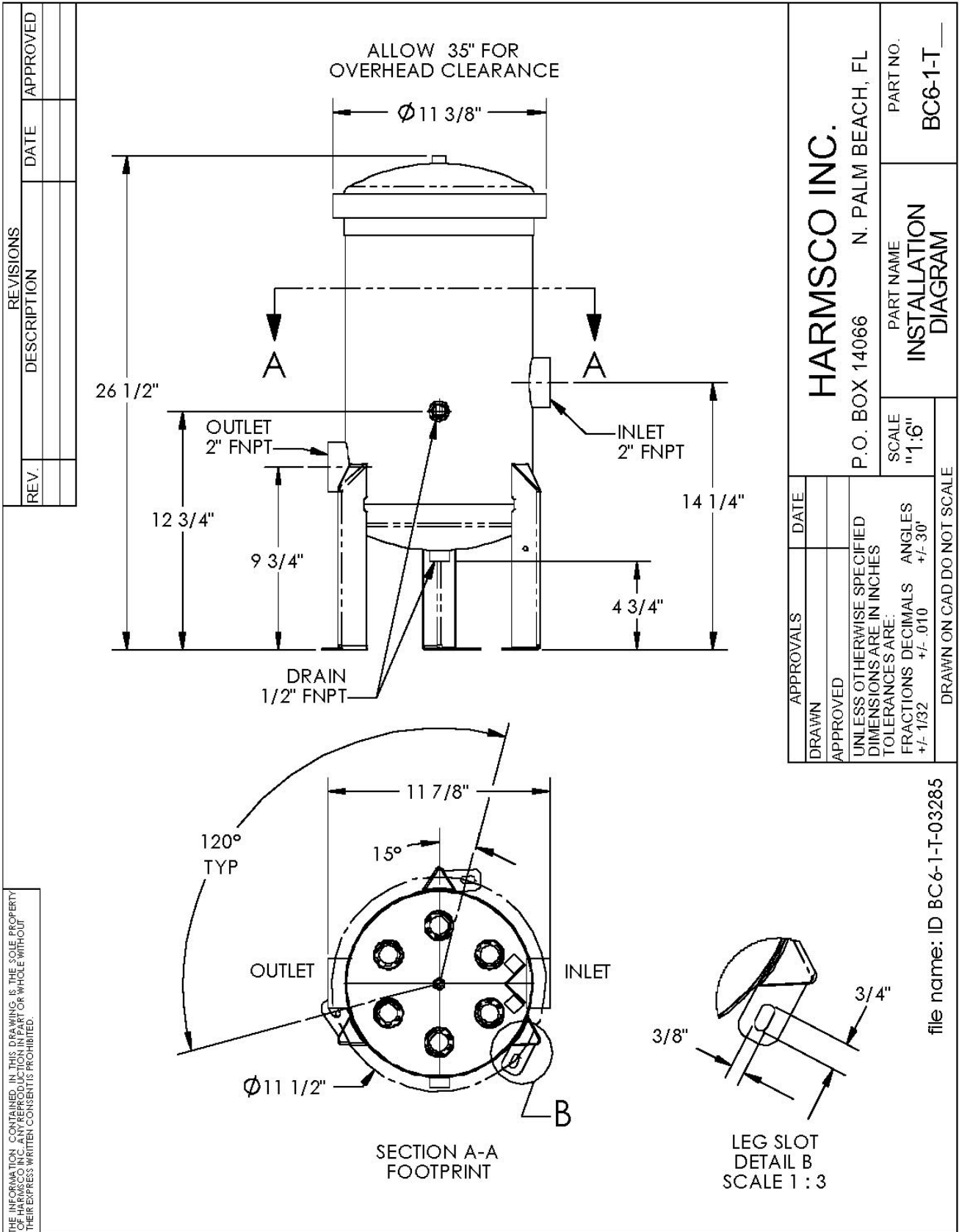

HARMSCO® Filtration Products

BC6 Series INSTALLATION AND OPERATION MANUAL

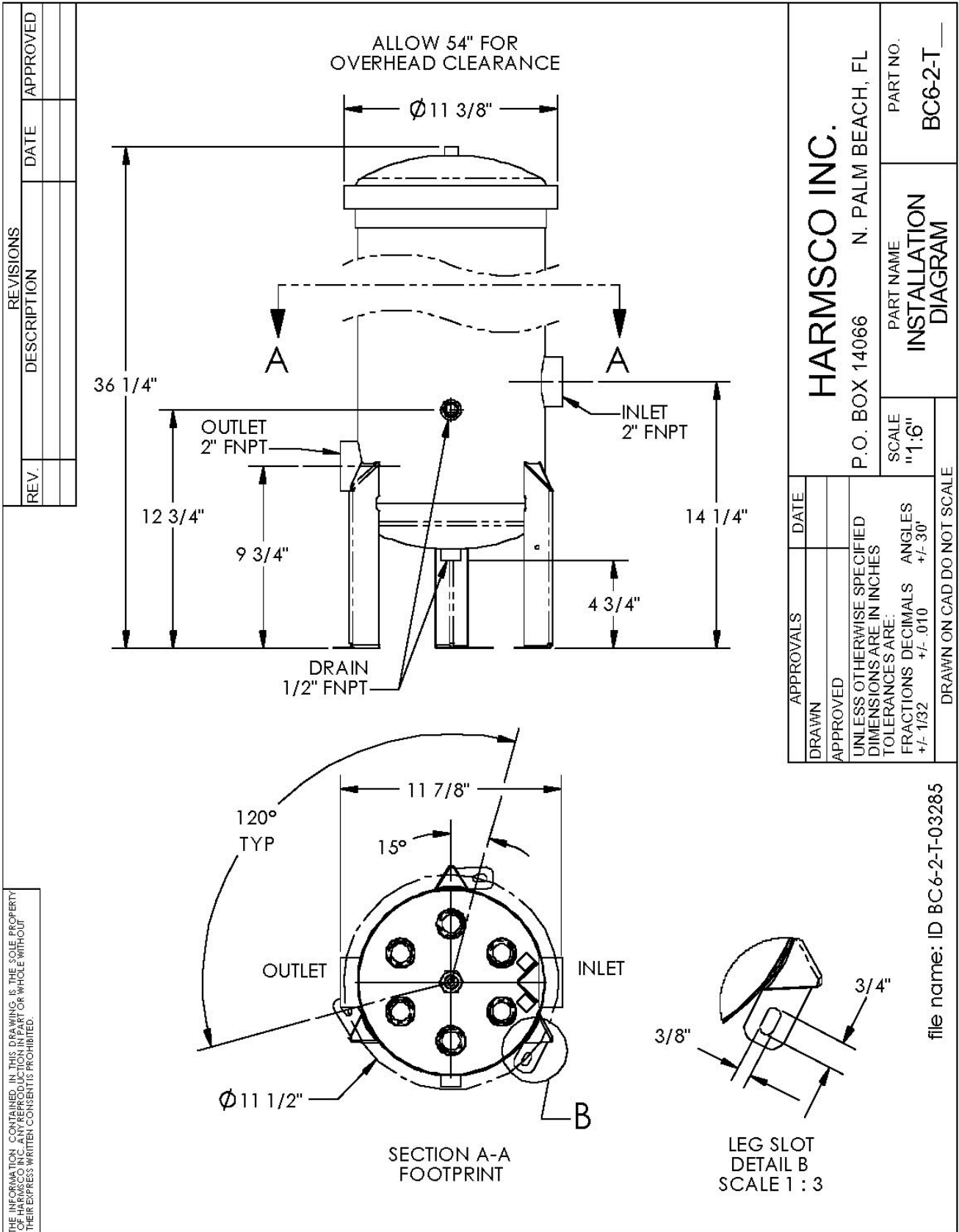

HARMSCO INC.
 P.O. BOX 14066 N. PALM BEACH, FL

PART NO. BC6-2-T

PART NAME
**INSTALLATION
 DIAGRAM**

SCALE "1:6"

THE INFORMATION CONTAINED IN THIS DRAWING IS THE SOLE PROPERTY OF HARMSCO INC. ANY REPRODUCTION IN PART OR WHOLE WITHOUT THEIR EXPRESS WRITTEN CONSENT IS PROHIBITED.

HARMSCO® Filtration Products

BC6 Series INSTALLATION AND OPERATION MANUAL

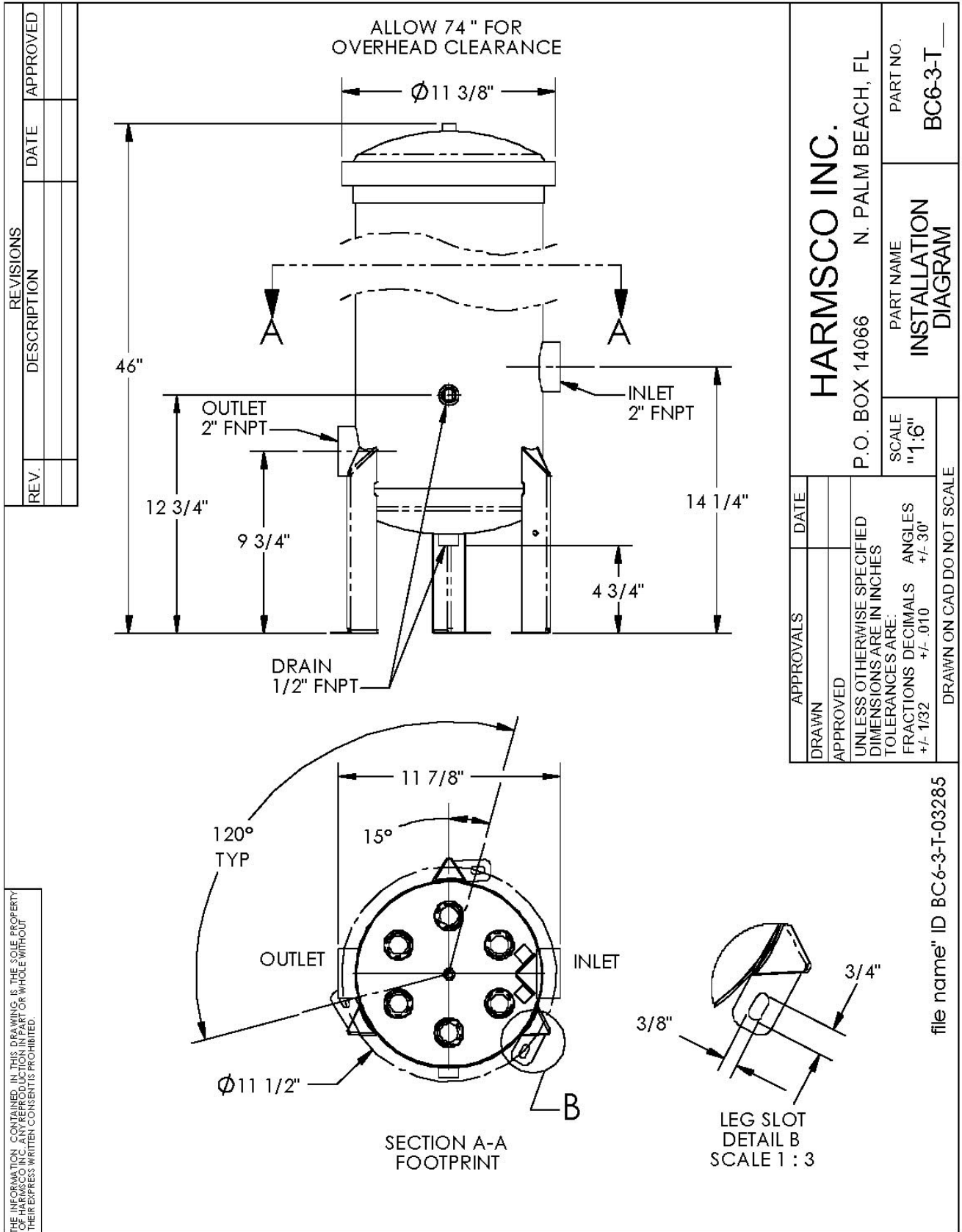

HARMSCO® Filtration Products

BC6 Series INSTALLATION AND OPERATION MANUAL

PARTS DIAGRAM

Unless specified, parts are common to all units.

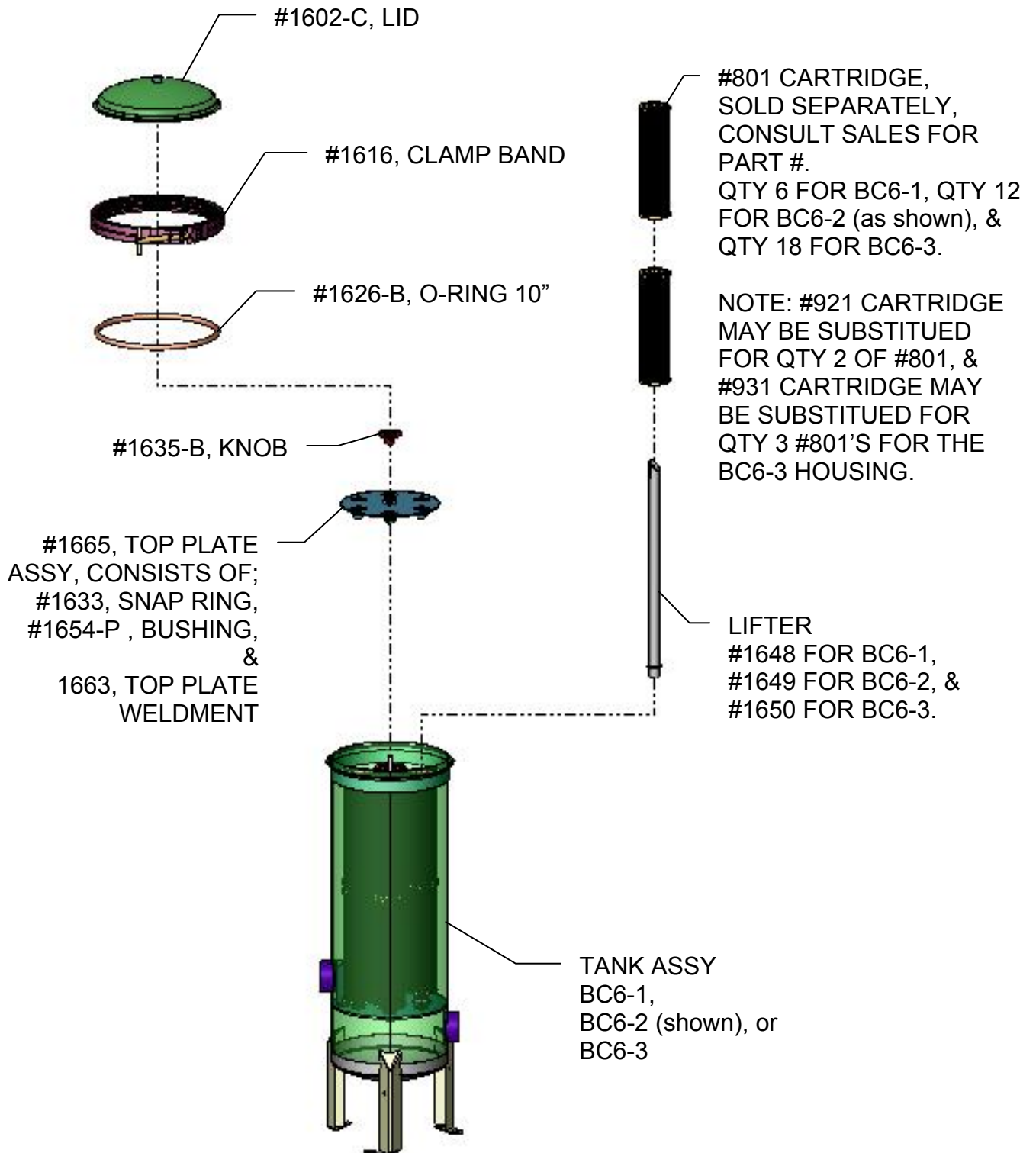

HARMSCO® Filtration Products

BC6 Series INSTALLATION AND OPERATION MANUAL

OPERATION

Description:

The BC6 series filters come in three sizes, BC6-1, -2 & -3, which represent the number of levels of #801 cartridges, and consists of a housing, lid, lifter rods (qty 6), top plate assembly, and a clamp band & O-ring housing seal. Each level will contain six cartridges that are internally supported by the lifter rod and are sealed to the housing by the top plate assembly to prevent by-pass. The housing is divided into two chambers; an upper, "inlet", chamber, which is where the cartridge filters are, and lower, "outlet", chamber. All metallic components are made of 300 series stainless steel.

The cartridges (filter cartridges) are sold separately and available in a wide variety of materials and functional pore sizes. Please consult with your Sales/Application Engineer to properly select the correct filter that will achieve your desired requirements.

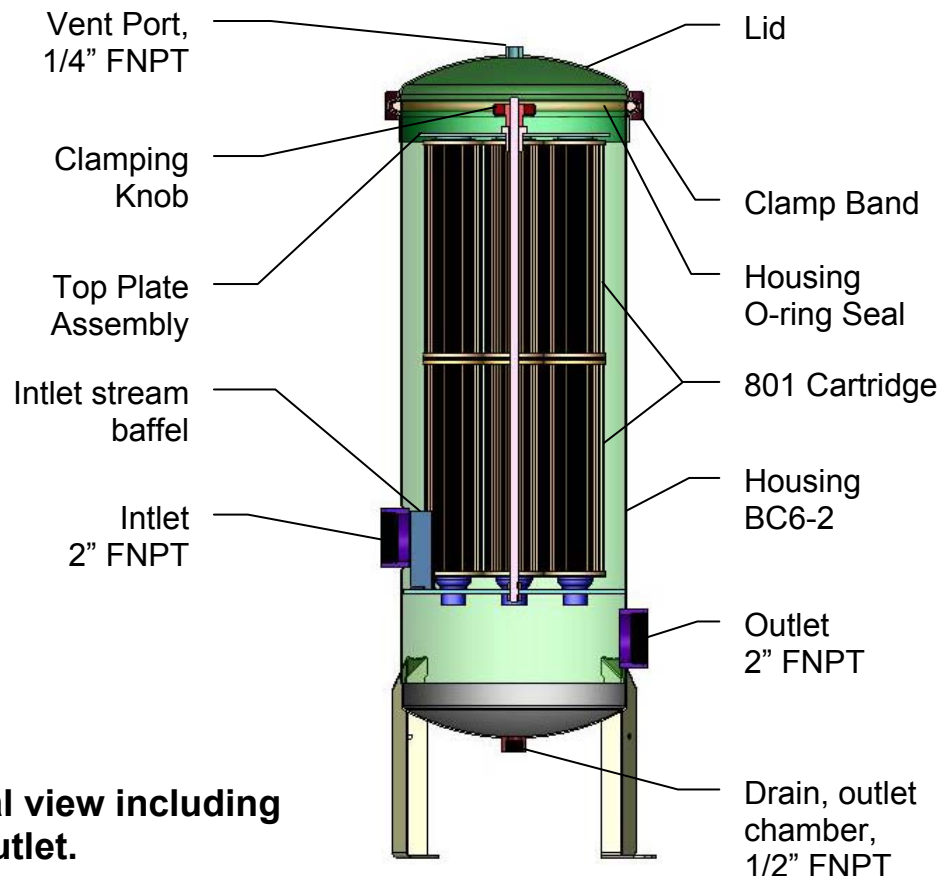

Cross sectional view including the inlet and outlet.

HARMSCO® Filtration Products

BC6 Series INSTALLATION AND OPERATION MANUAL

OPERATION cont.

Water enters the housing through the inlet located in the upper chamber. There is a baffle that protects the cartridges from the force that is generated by the inlet flow. Once in the upper chamber, the water must then flow through the filtering media of the cartridges and up to the open end of the lifting rod located in the center of each cartridge. Water will then enter the inside of the lifting rod and travel down and through the housing's tube sheet to the outlet chamber and then to the outlet port. The tube sheet is integrally welded to the housing and contains sealing cups that work in conjunction with similar features in the top plate assembly to create and maintain the necessary bypass seals. The cartridge end caps seal against themselves when assembled.

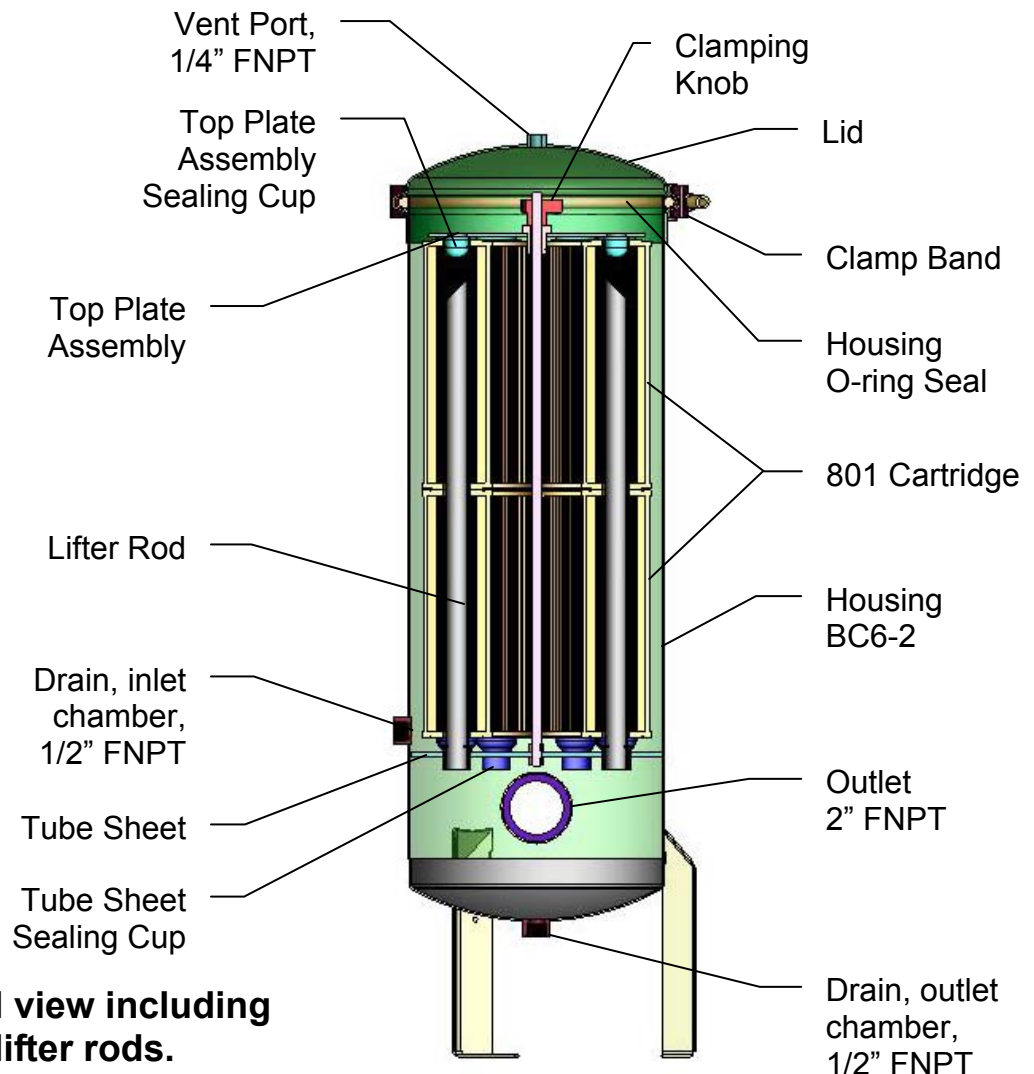

Cross sectional view including cartridges and lifter rods.

HARMSCO® Filtration Products

BC6 Series INSTALLATION AND OPERATION MANUAL

OPERATION cont.

Cartridge Replacement:

1. Isolate Housing from all fluid flow and relieve pressure.
2. Drain Housing.
3. Un-screw "T" Handle of Clamp Band.
4. Disengage "T" bolt of "T" handle from Clamp Band and remove Clamp Band. "T" handle and bolt should stay connected and loosely attached to Clamp Band.
5. Remove Lid.

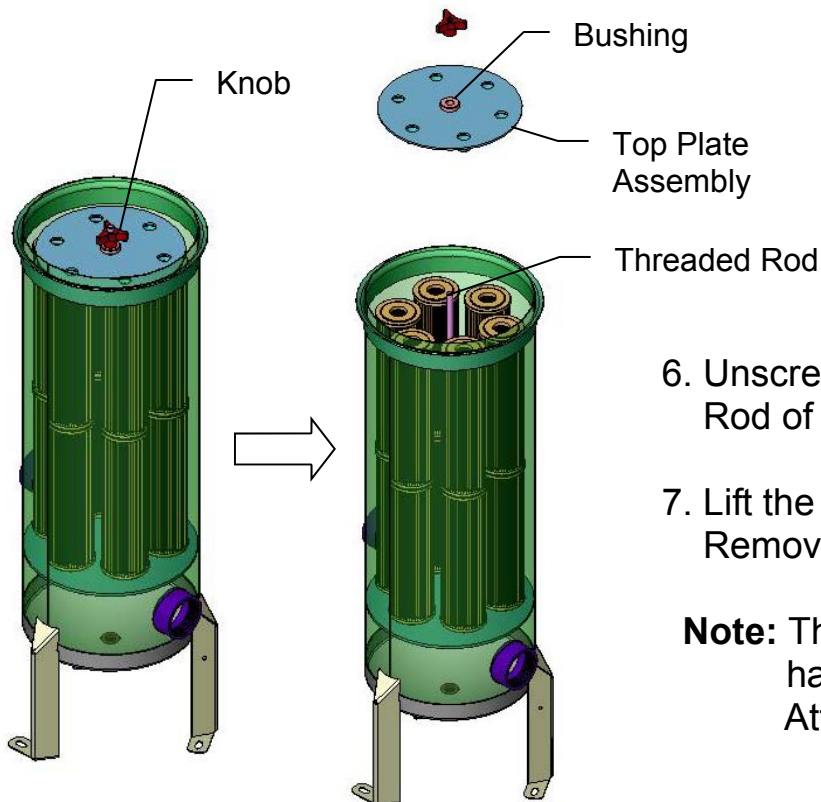
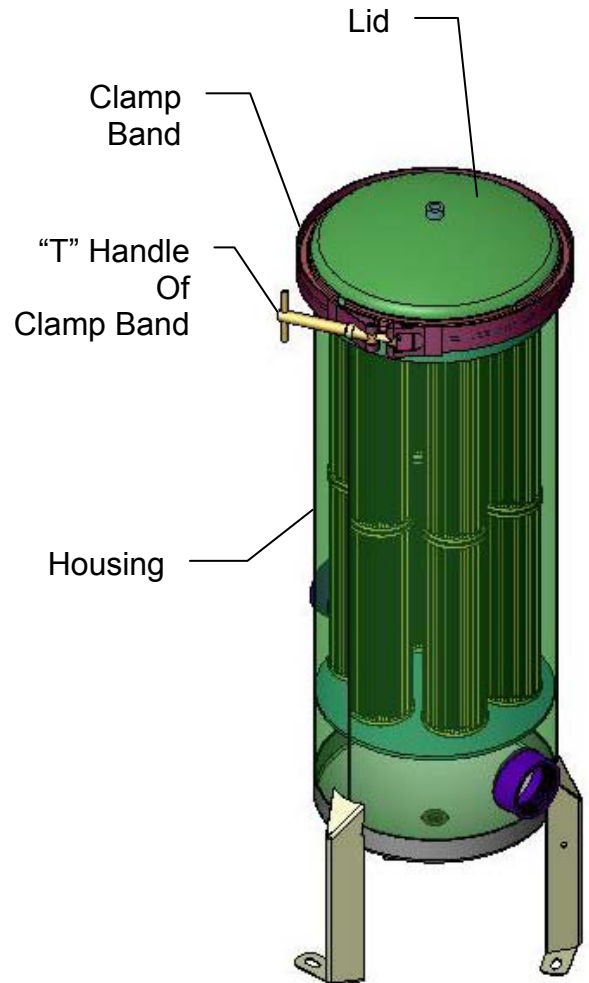

6. Unscrew Knob from the Threaded Rod of the Housing and remove.
7. Lift the Top Plate Assembly and Remove.

Note: The Bushing can be used as a handle and will remain loosely Attached to the Top Plate.

HARMSCO® Filtration Products

BC6 Series INSTALLATION AND OPERATION MANUAL

OPERATION cont.

8. Remove Cartridges from Housing.

Note: For BC6-2 & BC6-3, remove the upper cartridges, then use the lifting rod to extract the lower cartridges.

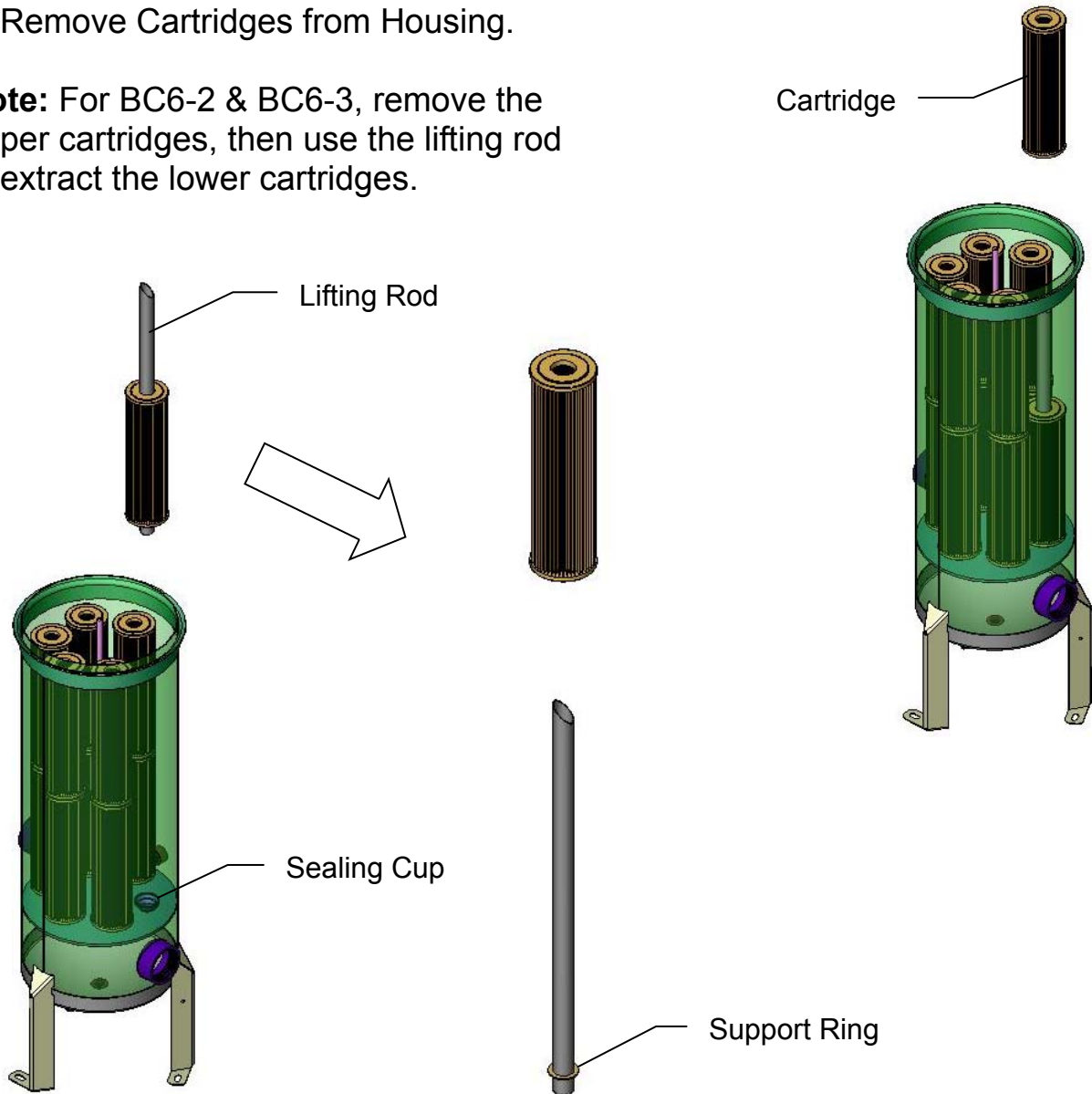

9. Replace Lifting Rods into Sealing Cups of Housing. Support Ring is to contact Inside of Sealing Cup.

10. Position new Cartridges onto Lifting Rods.

Note: Cartridges and Lifting Rods will be loose inside Housing.

HARMSCO® Filtration Products

BC6 Series INSTALLATION AND OPERATION MANUAL

OPERATION cont.

11. Install the Top Plate Assembly onto the Threaded Rod. Align the Domes of the Top Plate Sealing Cups with the Cartridges and engage.

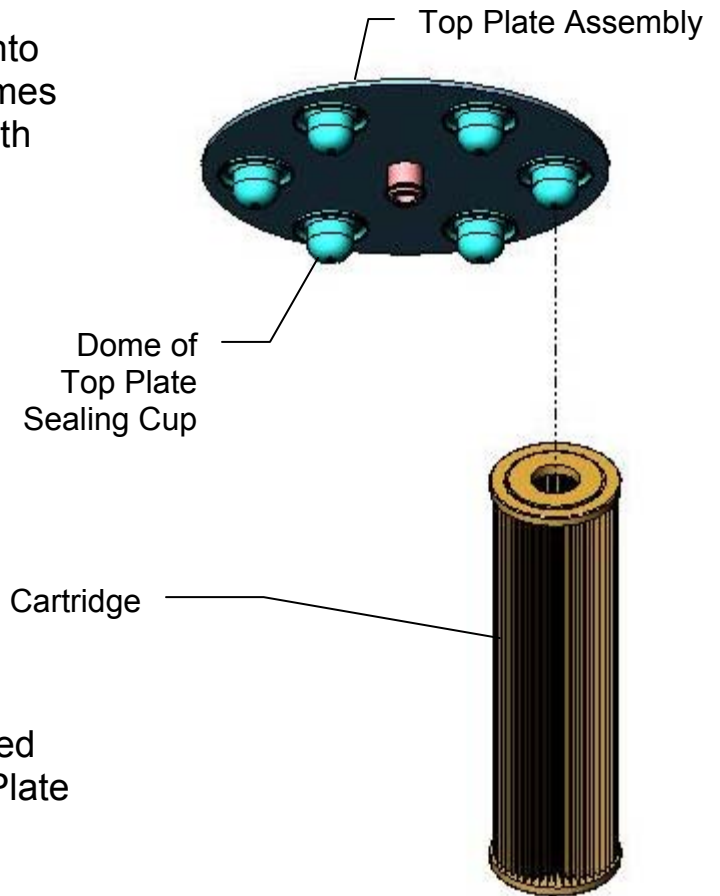

12. Install the Knob onto the Threaded Rod and hand tighten onto Top Plate Assembly.

13. Remove, inspect, and clean Housing O-ring Seal.

14. Clean the Housing Flange.

15. Place the Housing O-ring Seal onto the Housing Flange.

16. Clean the Cover and replace. The outside diameter of the Cover is to line up with the Housing Flange.

17. Install the Clamp Band and re-engage the "T" bolt.

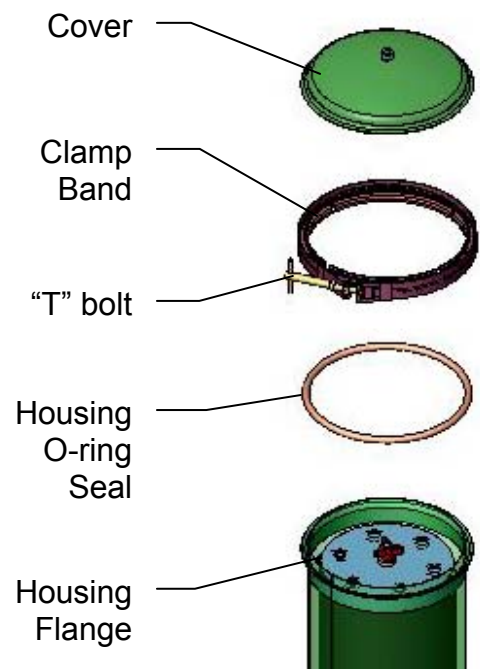

HARMSCO® Filtration Products

BC6 Series INSTALLATION AND OPERATION MANUAL

OPERATION cont.

18. Rotate "T" handle to tighten clamp band while ensuring proper engagement of clamp to flanges.

Note: It might be necessary to strike the clamp in an inward radial direction and all around circumference with a mallet to prevent sticking between clamp and flanges.

19. Open flow valves and resume operation.

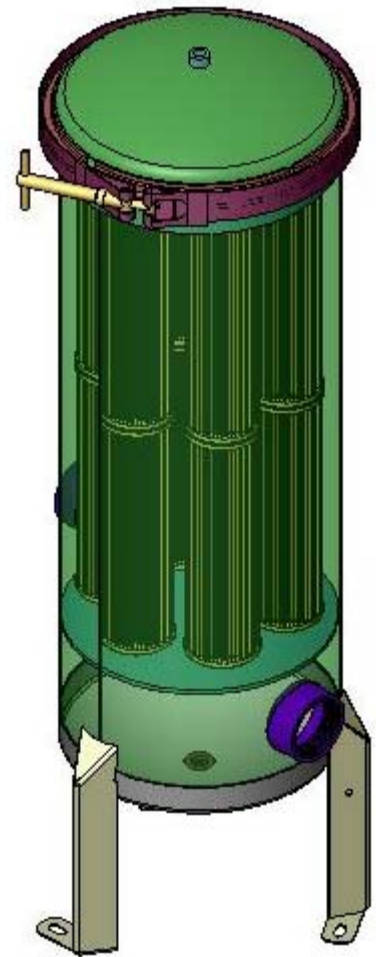

HARMSCO®

BC6 Series Water Filters

Specifications:

Description:	Model		
	BC6-1	BC6-2	BC6-3
Rated Flow Rate, gal/min	30	60	90
Height, inches	26 1/2	36 1/4	46
Service Height, inches	35	54	74
Housing Diameter	10"	10"	10"
Inlet/Outlet	2" FPT	2" FPT	2" FPT
Height of Inlet, inches	14 1/4	14 1/4	14 1/4
Height of Outlet, inches	9 3/4	9 3/4	9 3/4
Weight, Housing dry	31 lbs.	38 lbs.	44 lbs.
Weight, Cartridge dry*	6 lbs.	12 lbs.	18 lbs.
Weight, Full (Water + Housing + Cartridge)	75 lbs.	110 lbs.	147 lbs.

Cartridge Construction:

Qty of 801 style cartridges	6	12	18
Area of Media*	36 ft ²	72 ft ²	108 ft ²

Housing Construction:

Material:	Low Carbon Stainless Steel		
Inlet/Outlet:	2" FPT (see above)		
Drain (qty 2):	1/2" FPT		
Pressure Rating:	150 psi.		
Max Rated Flow, gal/min	30	60	90

Electrical Requirements:

Housing is to be properly grounded in accordance with electrical codes that govern the installation's jurisdiction.

* - Total quantity for 801 cartridges

**Harmsco BC6 Filter Housing Flow Curve.
Pressure drop shown is for BC6-3 filter housing with
20 micron filter cartridges in clean water.**

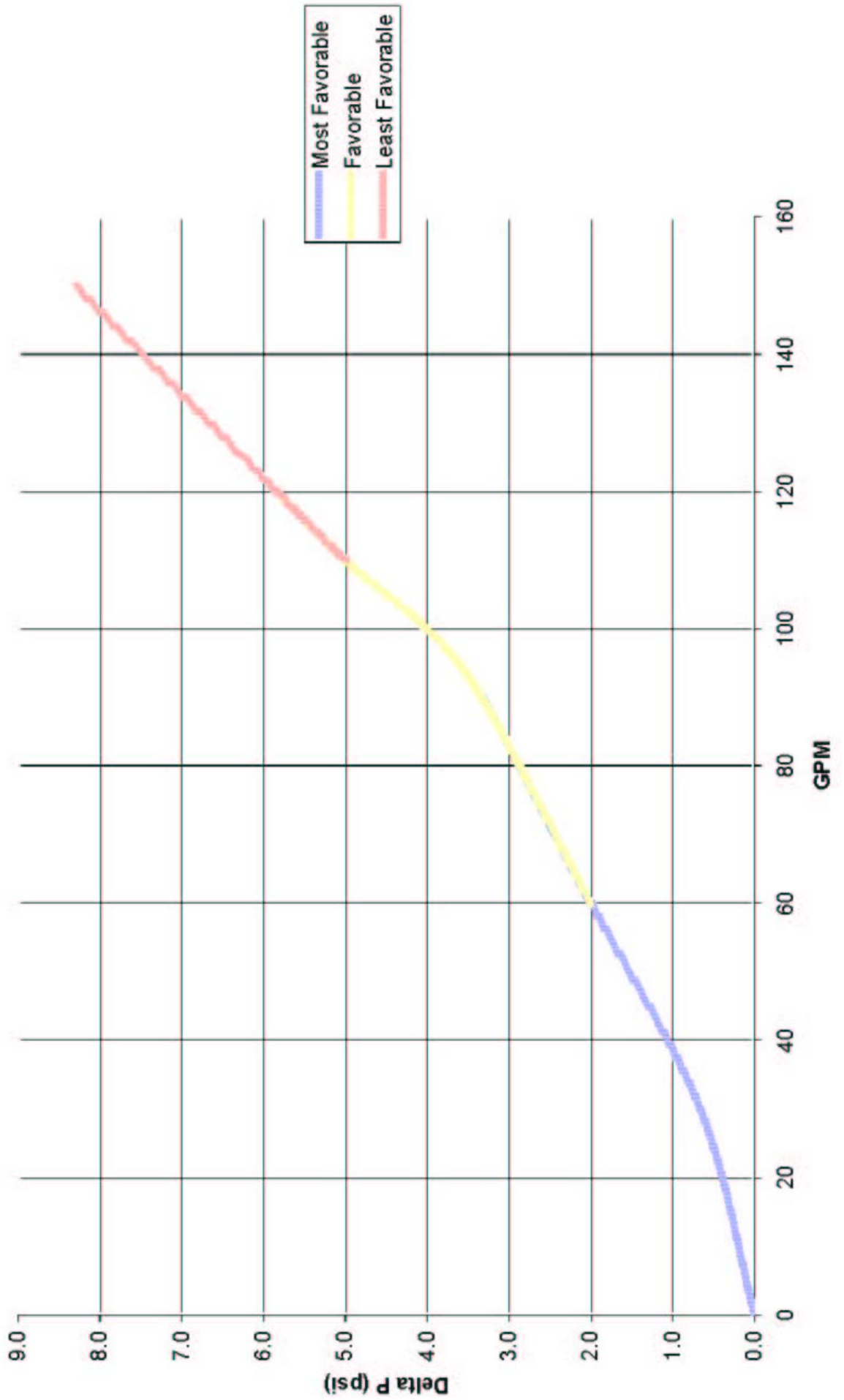

HARMSCO® BC6 Series Filters

**** NOTICE ****

THE FOLLOWING INSTRUCTIONS MUST BE READ AND FOLLOWED PRIOR TO USE.

Filter Cartridge Maintenance Instructions: For Filter Housings With “V” Shaped Band Clamp Closure.

1. **Always Remove Pressure From Housing Before Servicing.** Housing is to be shut off and drained of fluid.
2. Open filter housing by turning clampband "T" handle counter-clockwise.
3. Remove cartridges from packaging.
4. Make sure center cores are clear of all obstructions, mainly from shipping materials.
5. Insert Cartridges into housing and onto lifting rods. First cartridges should come into contact with sealing cup of housing.
6. Position housing O-ring seal on flange and outside of housing wall.
7. Place Lid onto housing and properly align on seal before applying clampband. Do not allow tilting or cocking of Lid on gasket.
8. Position V-Band Clamp around housing and make certain clamp envelopes housing flange and lid flange. Tighten V-Band Clamp slowly ensuring proper engagement of clamp to flanges. Continue tightening clamp closure bolt. You might have to tap the clamp in an inward radial direction, and all around its circumference, with a mallet to prevent sticking between clamp and flanges.
9. Open Filter Housing Outlet valve.
10. Slowly open inlet valve to begin operation, allowing fluid to fill housing.
11. It is recommended to flush all air out of the system by running water through the filter for about 30 seconds to one minute.
12. Start pump, if applicable, and operate filter.

Should a leak appear at the clamp, relieve pressure and repeat steps 8 through 11. Always remove pressure from housing before servicing any part of filter.

This product is manufactured under one or more of the following patents: U.S. NO. 4,187,179; 3,720,322; CANADA NO. 977,693; GT. BRIT. NO. 1,372,014; W. GERMANY NO. 2,261,817; FRANCE NO. 7,246,864; EUROPEAN NO. 0,191,844, Other patents pending.

Harmsco® Filtration Products

With Patented Up-Flow Filtration Technology

www.harmsco.com

1-800-327-3248

Harmsco Inc. Industrial Filters Limited Warranty

1. Harmsco, Inc. warrants its line of Industrial Filters to be free of defects in material and workmanship for a period of one year from the date of installation.
2. The warranty for Industrial Filters ordered with special coatings is limited only to the recoating of the defective parts due to failure in materials or workmanship for one year from date of installation.
3. This warranty does not cover any equipment purchased for use in applications in which the product is not suited. It is the responsibility of the buyer to determine if a product is suitable for a particular application.
4. **THIS WARRANTY EXCLUDES THE FOLLOWING:**
 - A. Any fresh water unit installed for salt water use.
 - B. Damage caused by improper installation, operation or care.
 - C. Chemical attack.
 - D. Modification or alteration by other than Harmsco employees.
 - E. Rubber type parts and normal wear items i.e. "O" rings, rim gaskets, wing-nuts, pipe caps, holding rods.
 - F. Any costs of labor or expenses expended in the removal and/or installation of unit, or any surrounding device.
 - G. Damage caused by galvanic or electrolytic attack.
 - H. Altering or removing the Harmsco, Inc. information label.
 - I. Any unit not grounded.
5. Service under this warranty is to be provided by the distributor who sold the unit to the user. If the distributor is unable to provide warranty service, contact:

Harmsco, Inc., P.O. Box 14066
North Palm Beach, Florida, 33408, U.S.A.
Phone: (561) 848-9628 • Fax: (561) 845-2474

A Returned Goods Authorization (RGA) number must be received from the above office and placed on all shipments to and correspondence with Harmsco, Inc. Please be prepared with the following information: 1. Model number and serial number. 2. Date of installation. 3. Name of installer 4. Nature of problem. 5. Your address and telephone number.

Available from:

Harmsco is a registered trademark of Harmsco, Inc.
©2002 Harmsco, Inc. Printed in U.S.A. Literature No. IO0902-10M

Toll Free: **(800) 327-3248**
Fax: **(561) 845-2474**
Local: **(561) 848-9628**
E-mail: **sales@harmsco.com**



Harmsco® Filtration Products

P.O. Box 14066, North Palm Beach, Florida 33408