

Good Water Warehouse Inc.  
1700 E Walnut Ave  
Fullerton CA 92831  
(714) 441-2893  
(714) 441-0525 FAX

# Goldline RO



## Reverse Osmosis System Installation & Service Guide



**Model # GOLDLINE-50**

**System Conforms to NSF/ANSI Standard 58  
for Performance Class**

System Tested and Certified by NSF International against NSF/ANSI Standard 58 for the reduction of the claims specified on the Performance Data Sheet (page 3)



System Tested and Certified by NSF International against NSF/ANSI Standard 58 for the reduction of the claims specified on the Performance Data Sheet (Page 3)

*Please read this manual carefully  
before attempting installation.*

# Goldline Manual Introduction



The Goldline RO System conforms to NSF/ANSI Standards 58 for performance claims as verified and sustained by test data. All pre and post filtration demands were removed prior to contaminant reduction performance testing by the Water Quality Association laboratory.



The Goldline reverse osmosis drinking water system is designed for easy installation and maintenance. You will insure a successful installation as well as reliable operation by carefully reading this manual and following the operational guidelines. Please note that routine maintenance is essential to the longevity and performance of the system. Filters should be changed every six months (see below) depending on the quality of the feed water supply. **The Goldline RO installation should comply with all state and local laws and regulations. Manufacturer recommends a TDS test every six months.** This system is acceptable for treatment of influent concentrations of no more than 27 mg/L nitrate and 3 mg/L nitrite in combination measured as N and is certified for nitrate/nitrite reduction only for water supplies with a pressure of 40 psig or greater. This reverse osmosis system contains a replaceable component critical to the efficiency of the system. Replacement of the reverse osmosis component should be with one of identical specifications, as defined by the manufacturer, to assure the same efficiency and contaminant reduction performance.

Necessary Installation Tools	
• Variable speed drill	• Teflon tape
• Relton Drill	• Small knife
• 1" hole saw	• Phillips screw driver

Recommended Filter & Membrane Replacement Schedule		
Filter/Membrane	Part #	Frequency
Sediment	93023	6 months
Carbon Block Prefilter	32-250-125-975	6 months
Carbon Postfilter	CL10ROT40-B	6 months
* RO Membrane	1204694	2-5 years

## Conditions for operation of TFC - Thin Film Composite Membrane Used in the Goldline-50

Source Water Supply - TFC	
Community / Private	Bacteriologically Safe
System Pressure min/max	30 / 100 psi
Temperature	4° / 38°C (40° / 100° F)
pH Range	3.0 to 11.0
Maximum supply TDS level	1800 mg/L
Turbidity	< 1.0 net turbidity (NTU)

Chemical Parameters - TFC	
Hardness (CaCO <sub>3</sub> )	< 170 mg/L (< 10 gpg)
Iron (Fe)	< 0.1 mg/L
Manganese (Mn)	< 0.05 mg/L
Hydrogen Sulfide (H <sub>2</sub> S)	0.00 mg/L
Production Rate	
<sup>1</sup> Efficiency Rate	8.67%
<sup>2</sup> Recovery Rate	23.87 %
Daily Production Rate	11.19 gpd

Test parameters: 25± 1°C, 50 psi and pH of 7.5

<sup>1</sup> Efficiency rating means the percentage of the influent water to the system that is available to the user as reverse osmosis treated water under operating conditions that approximate typical daily usage

<sup>2</sup> Recovery rating means the percentage of the influent water to the membrane portion of the system that is available to the user as reverse osmosis treated water when the system is operated without a storage tank or when the storage tank is bypassed.

**Caution:** Do not use with water that is microbiologically unsafe or of unknown quality without adequate disinfection before or after the system. Systems certified for cyst reduction may be used on disinfected water that may contain filterable cysts

# Good Water Warehouse Inc.

GWW Inc.  
1700 E Walnut Ave  
Fullerton CA 92831  
(714) 441-2893  
(714) 441-0525 FAX

## Good Water Warehouse Reverse Osmosis System

### NSF 58

Part Number: GOLDLINE-50

Systems Tested and Certified to NSF/ANSI 58

### General installation / Operation / Maintenance Requirements

1. Do not use with water that is microbiologically unsafe or of unknown quality without adequate disinfection before or after the system. Systems certified for cyst reduction may be used on disinfected water that may contain filterable cysts.
2. No iron present in feed water to R.O. System
4. Hardness of more than 7 grains may shorten membrane life
5. Manufacturer recommends a TDS test every six months
6. Efficiency rating means the percentage of the influent water to the system that is available to the user as reverse osmosis treated water under operating conditions that approximate typical daily usage.
7. Recovery rating means the percentage of the influent water to the membrane portion of the system that is available to the user as reverse osmosis treated water when the system is operated without a storage tank or when the storage tank is by passed.
8. This system is acceptable for treatment of influent concentrations of no more that 27 mg/L nitrate and 3 mg/L nitrite in combination measured as N and is certified for nitrate/nitrite reduction only for water supplies with a pressure of 40 psi or greater.
9. The Goldline-50 installation should comply with all state and local laws and regulations.
10. This Reverse Osmosis System contains a replaceable treatment component critical for effective reduction of total dissolved solids. The product water shall be tested periodically to verify that the system is performing satisfactorily.
11. See owners manual for manufacturer's limited warranty, installation, operation and maintenance requirements.
12. This system has been tested and shown to operate at its calculated recovery rating, or efficiency rating, or both under standard test conditions. Test parameters: 25°± 1°C, 50 psi and pH of 7.5.
13. Chlorine in the influent water may affect the RO membrane polymers.

This system has been tested according to NSF/ANSI 58 for reduction of substances listed below. The concentration of the indicated substances in water entering the system was reduced to a concentration less than or equal to the permissible limit for water leaving the system, as specified in NSF/ANSI 58.

Testing was performed under standard laboratory conditions, actual performance may vary.

Contaminant	Ave. Influent (mg/L)	Ave. Effluent (mg/L)	Ave. % Reduction	US EPA MCL (mg/L)
* Barium	9.4	0.58	93.8	0.84
Cadmium	0.03	0.0004	98.7	0.0006
Chromium (Hexavalent)	0.29	0.026	91.2	0.033
Chromium (Trivalent)	0.32	0.017	94.8	0.022
Copper	3.0	0.033	98.9	0.066
Fluoride	8.6	0.4	95.6	0.5
Lead	0.15	0.002	98.7	0.003
Radium 226/228	25 pCi/L	5 pCi/L	80.0	5 pCi/L
Selenium	0.099	0.004	96.0	0.004
Turbidity	11 NTU	0.1 NTU	99.0	0.2 NTU
TDS	739	45	93.8	82

Daily Production Rate	11.19 gpd
Recovery rate	23.87 %
Pressure Drop at Rated Flow	5 psi
System Weight	30 lbs
Efficiency Rating	8.67 %
Min. / Max. Pressure	30/100 psi
Min. / Max. Temperature	4°/38°c (40°/100° F)
Production Storage Capacity	2.4 gallons

Test parameters: 25°± 1°C, 50 psi and pH of 7.5

#### Recommended Replacement of Membrane and Filters

R.O. Membrane	1204694	2 to 5 years
Sediment Prefilter	1227867-V	6 months
Carbon Block Prefilter	32-250-125-975	6 months
Carbon Block Prefilter	32-250-125-975	6 months
Post Carbon Filter	CL10ROT40-B	6 months

A performance indicator will monitor the performance of the RO membrane, a critical component for the reduction of the above contaminants

#### WQA certified for the reduction of:

TDS, Barium, Cadmium, Hexavalent and Trivalent Chromium, Lead, Radium 226/228, Selenium, Fluoride, Nitrite, Nitrate

Refer to owners manual for additional maintenance and warranty information



# Starting Your Installation

## Preparation

Check the following list of components to ensure that all parts are packed with your system.

Quantity	Item	✓
1 Each	Storage Tank	<input type="checkbox"/>
	RO System	<input type="checkbox"/>
	Faucet	<input type="checkbox"/>

Determine the location for the installation of the RO system. Avoid locations where the system might come in contact with hot water pipes or other hazards. Determine the location for the faucet. Check to see that drilling the faucet hole will not damage pipes or wires running underneath the sink. Determine the location for the storage tank. A maximum distance from tank to faucet of 15 feet is possible. The system will produce a faster flow at the faucet with the shortest tubing run from tank to faucet.

Check to see that no damage has occurred during shipment, all connectors are secure, and there are no leaks once the system is hooked up. Close inspection of the system should be performed during the first week of operation.

## Shutting Off the Water

Locate the water shut-off valve for the cold water feed line you choose to use for the supply. Accidentally hooking up the system to the hot supply line will permanently damage the membrane (See Conditions for operation). To assure you are using the cold water line, turn on both the hot and cold faucet. After the water is warm to the touch, feel the pipes under the sink. It will be easy to identify the hot and cold pipes.

Close the cold water valve. Turn on the cold water faucet only to assure that the line is completely shut off and the line is drained. If no shut off valve is located under the sink, turn off the main supply at the entry to the house.

## Fittings and Tubing

Easy Fit fittings are used throughout the system with the exception of the supply feed and drain connector. To insure an optimal seal, tubing should be cut with the end square. An angled cut or distortion of the tubing will not provide an efficient seal and may cause leaks.

To install a tube, push it through the collet until it seats firmly. To remove a tube, push in the collet and pull out the tube.

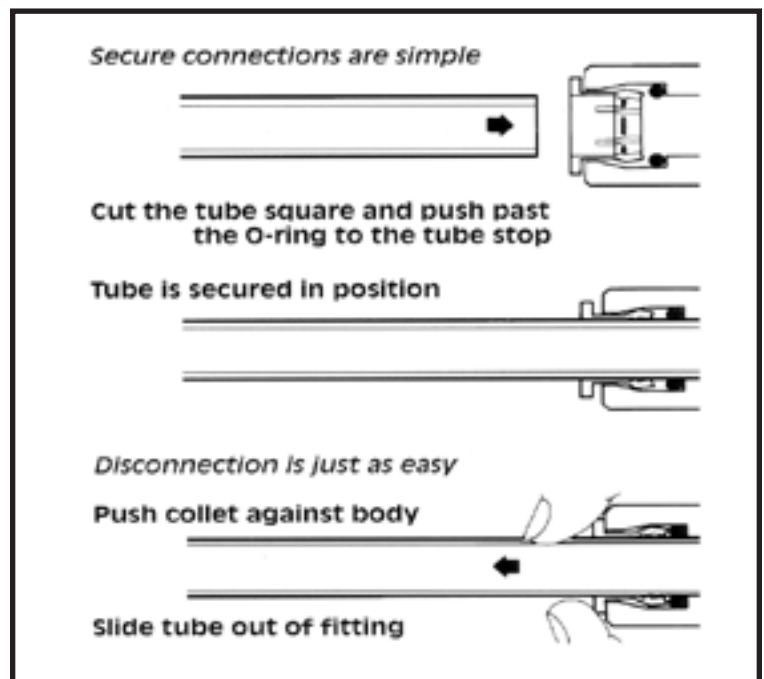

Fittings & Tubing Diagram

Compression fittings are used on the supply feed and drain connector. To insure an optimal seal, tubing should be cut with the end square. An angled cut or distortion of the tubing will not provide an efficient seal and may cause leaks.

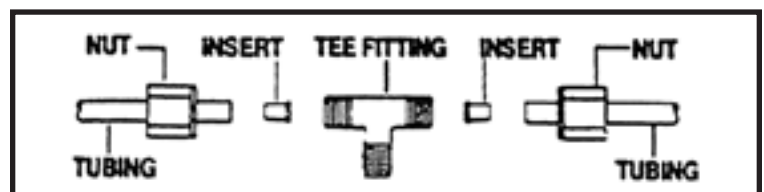

Compression Fittings Diagram

# Installation

## Supply Feed Installation

(A) **Flex Line:** Loosen nut and separate cold water riser tube from faucet shank. Gently bend riser tube so that slip joint fits onto faucet shank. Replace the existing cone washer with new washer provided in installation kit onto cold water riser tube. Reinstall riser tube onto slip joint adapter and tighten.

(B) **Solid Copper Riser Tube:** Same procedure as flex tubing except you must cut a piece of the riser tube about 3/4" to 1" so the slip joint adapter can fit between faucet and riser tube (Teflon tape must be used on slip joint adapter to prevent leaks).

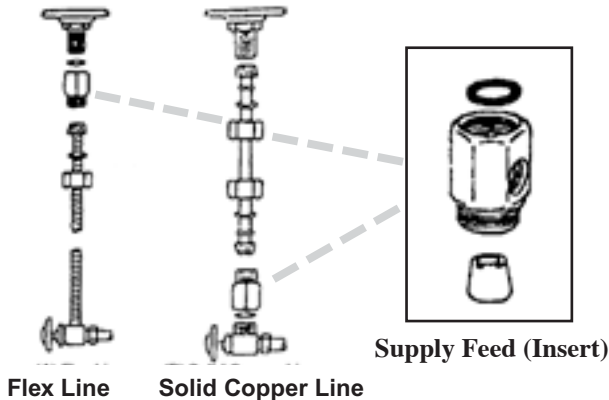

## Drain Clamp Installation

Select a location for the drain hole based on the design of the plumbing. Position the drain outlet saddle on the drain pipe. Allow adequate space for drilling. Tighten the bolts evenly on both sides. Avoid overtightening.

### Drain Clamp Assembly

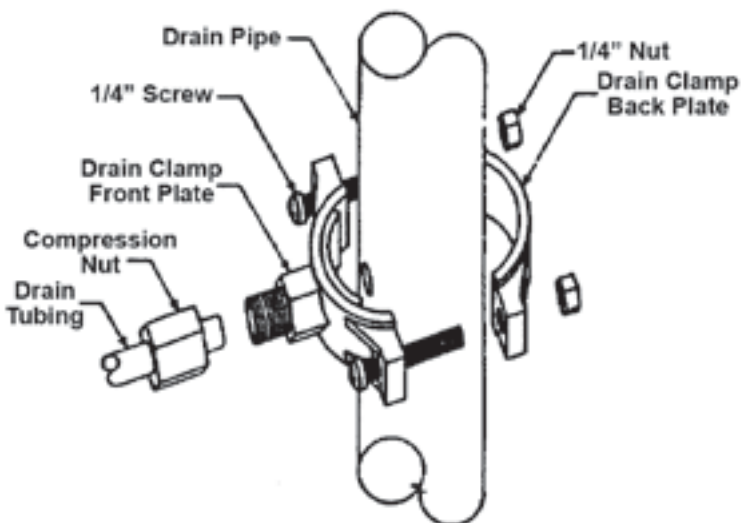

Using the opening in the drain outlet saddle as a guide, drill a 1/4" hole in the drain pipe. Clean debris from the saddle and threads.

## Mounting the Tank Ball Valve

(1) Wrap the threads on the top of the water storage tank 3 times with plumbers (Teflon) tape only. Make sure it is tight, but not over tight. (2) Connect the tank ball valve assembly to the top of the water storage tank. (3) Connect the tube from the RO membrane to the water storage tank.

*Note: Do not tamper with the air valve on the storage tank. It has been preset and screwed on with blue cap by the manufacturers.*

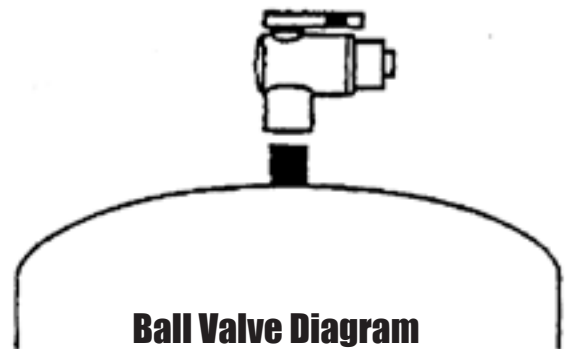

## RO Membrane Installation

Disconnect the easy fitting as shown in the diagram below. Remove the membrane housing head by turning counter clockwise.

### RO Membrane

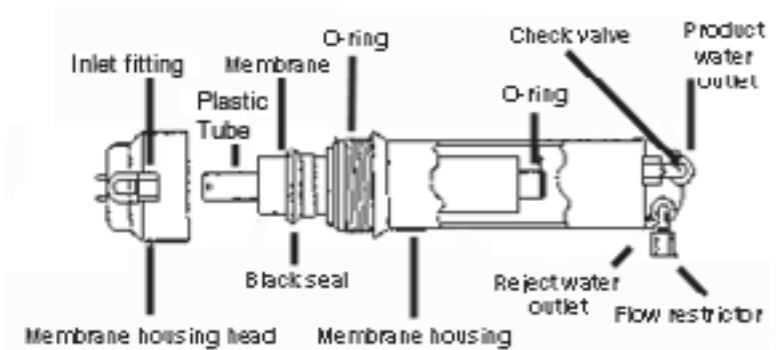

# Installation - Product Water Faucet

## Drilling the Faucet Hole

The product water faucet may be installed on any flat surface at least 2" in diameter. Check the underside of the location for interference.

## Porcelain/Enamel Sinks

A 1" variable speed drill is recommended for this procedure. A spring loaded Relton style drill set is strongly recommended to prevent chipping. The plastic sleeve supplied on the pilot drill is to be positioned on the drill bit against the drill chuck. This prevents the chuck from contacting the porcelain after the pilot hole has been completed. Avoid high motor RPM during the initial cutting of the porcelain as this can cause chipping.

## Drilling with the recommended Relton cutter

EASY AS ...

1



The Pilot Drill is used to drill a hole completely through to provide a guide for both the Porcelain Saw and Finish Hole Saw.

2



The Porcelain Saw is used to cut through the porcelain surface only. This saw cuts a smooth, chip-free, beveled groove through the porcelain to the metal base.

3



The Finish Hole Saw is used to cut the remaining metal through to create the hole of the desired finish size.

Using a carbide tipped drill bit, drill a pilot hole completely through the porcelain and the material underneath. Place the spring loaded porcelain saw into the drill chuck. Make sure the pilot guide is inserted tightly. Insert the pilot guide into the pilot hole. Push down gently on the drill motor to apply light pressure to the porcelain surface. Start the drill motor turning as slowly as possible. After the initial cut has started, motor speed may be gradually increased. The cut may require three to four minutes to complete. Going faster could result in excessive chipping. This saw is used to cut the porcelain only. Be sure a complete ring has been cut through the porcelain to the metal underneath.

Place the finish hole saw into the drill chuck. Make sure the pilot guide is inserted tightly. Insert the pilot guide into the pilot hole. Begin cut using a slow speed and light pressure until the metal has been penetrated.

## Stainless Steel Sink

Make a small indent to mark the desired drilling location using a center punch. Drill a pilot hole with a 1/8" metal drill bit. Enlarge the hole using a 1" metal drill bit.

## Air Gap Faucet Installation

Once the hole has been drilled place the chrome washer under the faucet body. Next, insert the rubber gasket under the chrome washer and locate the RO faucet in the hole. Install the lock washer and nut and then tighten firmly while aligning the faucet in the desired direction. Finally, connect the Easy Fit 3/8" fittings (in the installation kit) on the faucet shank using teflon tape.

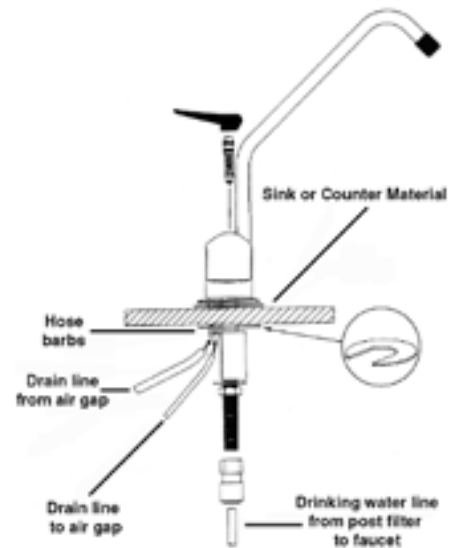

## Optional Ice Maker Hook-Up

If your refrigerator is less than 25 feet to your R.O. unit, 1/4" polypropylene plastic tubing is recommended. If your refrigerator is greater than 25 feet from your R.O. unit, 3/8" tubing is recommended. *Do not use copper tubing as an objectionable ice cube taste can result.*

To begin, install a tee in the blue tubing between the final filter and the faucet. Next, it is recommended to install a ball valve in the line to the ice maker. This will allow storage tank pressure to increase sufficiently for the ice maker solenoid to operate properly. Leave the ball valve in the closed position until the tank is full after start up procedure is completed, open ball valve.

# Installation Diagram & Tubing Guidelines

## Goldline Installation Diagram

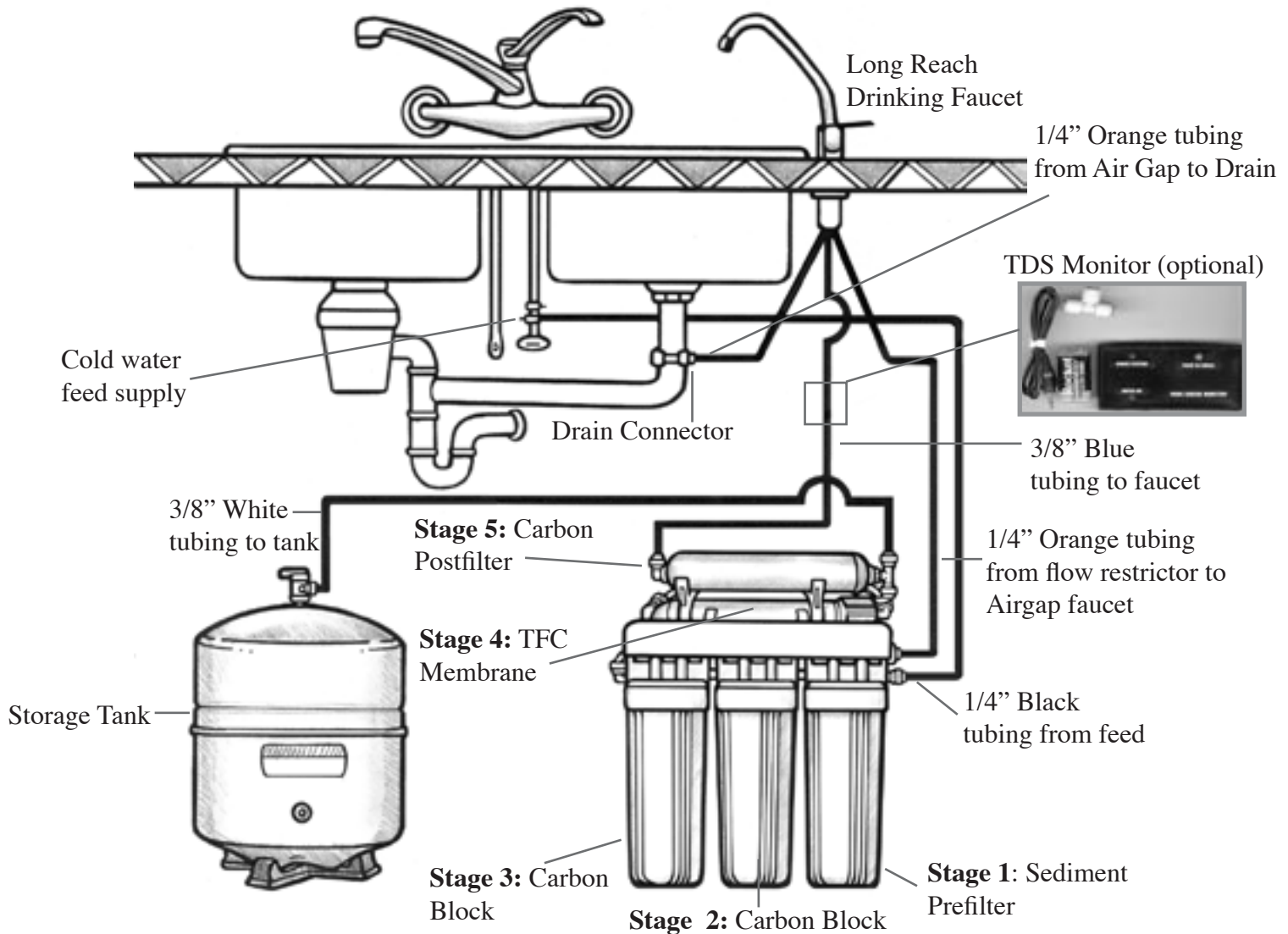

### Color Coded Tubing

Tubing	Directions
1/4" Black	Feed water supply line to inlet on sediment filter elbow labeled <b>feed</b>
3/8" Blue	Carbon post filter elbow labeled <b>faucet</b> to center threaded shank of faucet to faucet connector
3/8" White	Carbon post filter tee labeled <b>tank</b> to ball valve on storage <b>tank</b>
1/4" Orange	Flow restrictor labeled <b>drain</b> to airgap faucet. 1/4" barbed connector
3/8" Black	Airgap faucet 3/8" barbed connector to waste water drain connector

## *Do Not Use the First Two Reservoirs of Water*

Allow the reservoir to fill for 12 hours. Dispense this water to drain. This process removes the factory installed sanitizing solution from the entire system and sends it to the drain. Repeat this process one more time. Allow the tank to fill for 12 hours and dispense this water to the drain.



**Goldline-50**

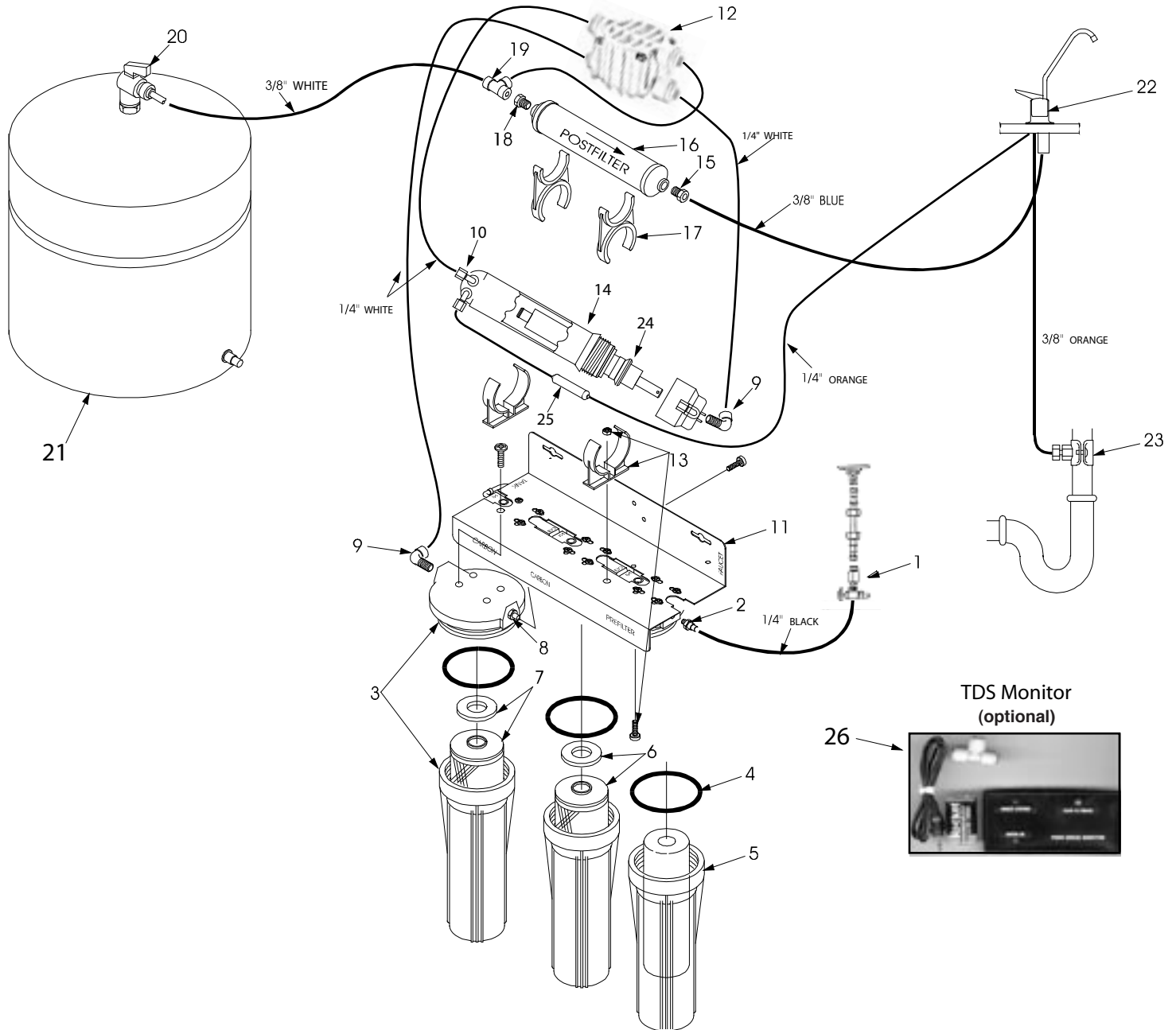

TDS Monitor  
(optional)



Please Call Your Local Water Professional or Good Water Warehouse For Parts Replacement

- |                           |                |                         |                |
|---------------------------|----------------|-------------------------|----------------|
| 1. Supply Feed            | 3095-8         | 14. Membrane Housing    | 144376         |
| 2. 1/4" Male Connector    | CI010822W      | 15. 1/4" Male Connector | CI010822W      |
| 3. Filter Housing         | 1H4WHWH        | 16. In-Line GAC         | CL10ROT40-B    |
| 4. Filter Housing 'O-Ring | 143026         | 17. Double Clip         | PPC205W        |
| 5. 5 Micron Filter        | 1227867-V      | 18. Stem Adaptor        | PI051222S      |
| 6. Carbon Block           | 32-250-125-975 | 19. Reducing Tee        | PI301208S      |
| 7. Carbon Block           | 32-250-125-975 | 20. Ball Valve          | 7070590        |
| 8. 1/4" Nipple            | N-14           | 21. Tank                | TKE-3200W      |
| 9. 1/4" Male Elbow        | CI480822W      | 22. Air Gap Faucet      | N103H3PIAG     |
| 10. Check Valve           | SCV-CI480821W  | 23. Drain Connector     | PDC60438M      |
| 11. Bracket               | A-FM60W        | 24. Membrane            | 1204694        |
| 12. ASO Valve             | FC-ASV4000JG   | 25. Flow Restrictor     | PFR402Q-300    |
| 13. 2.5 Clips             | PPC212W        | 26. TDS Monitor         | PURCHECK-1-3/8 |



# Activation, Care, & Troubleshooting

## Activating the System For the First Time

Make sure all water supply/drain lines are secure and free from leakage. Slowly turn the saddle valve counterclockwise until fully open. Check stem seal for leakage. If necessary tighten stem nut lightly. Turn storage tank valve one quarter turn counterclockwise to open the valve (the handle should be in line with the tubing as it enters the connection). Open the product water faucet and let the water flow until all the air has been expelled from the system. This will take about an hour. Close the product water faucet. In 30 minutes, check the connections for leaks and correct if necessary.

## Replacement Filter Procedures

Before starting the filter replacement shut off cold water supply, drain the storage tank by turning on the RO faucet, and shut off the storage tank ball valve. Once you have completed the preparation, first begin by twisting the housings counter clockwise with a filter wrench and remove the old filters. Then wash out the inside of the housing with mild soap and a few drops of household bleach and rinse out thoroughly. Finally, lube the O-ring on the filter housing, insert the new filters, and screw on the housing in a clockwise direction.

## System Sanitization

It is recommended to sanitize your system **once per year** when you are changing the filters. Start by shutting off the cold water supply and draining the storage tank by turning on the RO faucet. Once this is completed remove the filters and membrane and put 1/2 teaspoon of household bleach in the sediment filter housing. Then run water through the system until water begins pouring out the RO faucet. Close the faucet, allow the bleach to remain in the system for three minutes, and then slowly drain the water from the system for five minutes. Finally, reinstall the filters and membrane.

Troubleshooting		
Problem	Reason	Solution
Water has an offensive odor / taste	Carbon post filter is depleted	Drain storage tank & replace post filter
Water has an offensive odor / taste	Filters are depleted	Replace filters & sanitize system
Not enough product H <sub>2</sub> O Pressure	Storage tank air pressure is low	Empty storage tank and set pressure to 8 psi (55kPa)
Not enough water	Low water pressure	If line pressure is below 30 psi install a booster pump
Not enough water	Water supply is blocked	Clear restriction, rotate valve on feed water
Not enough water	Storage tank is depleted	Consider an increase in tank or membrane capacity
Not enough water	Clogged pre-filter cartridge	Replace prefilter, drain tank and sanitize system
No drain water	Clogged flow restrictor	Replace flow restrictor, check TDS monitor
No water	Water supply is turned off	Turn water on
Under sink is wet	Leak from valve, faucet or fitting	Dry everything with towels to isolate leak, identify and fix.

# GoldLine Limited Warranty

The Goldline reverse osmosis system is warranted to be free from defects in materials and workmanship under normal use within the operating parameters listed below. For a period of three years from the date of purchase Good Water Warehouse will repair or replace any part of the reverse osmosis system with the exception of the filters and membrane.

## Conditions of Warranty

The above warranty does not apply to any part of the Goldline reverse osmosis system that is damaged because of neglect, misuse, alteration, accident, misapplication, physical damage, fouling, and/or scaling of the membrane by minerals, bacterial attack, sediment or damage caused by fire, freezing, hot water, or an act of God.

Good Water Warehouse assumes no warranty liability in connection with this reverse osmosis system other than as specified herein. Good Water Warehouse shall not be liable for consequential damages of any kind or nature due to the use of Goldline-50 product.

## Good Water Warehouse will provide warranty service under the following conditions:

- 1) Contact your local dealer who will obtain return authorization instructions.
- 2) Ship the unit or part freight prepaid for warranty evaluation or service. Unit must be returned in the original carton or packaged to prevent possible damage. Systems or parts covered under the warranty shall be repaired (or, at our option replaced) and returned without charge.

## Conditions for operation of TFC - Thin Film Composite Membrane Used in the Goldline-50

Source Water Supply - TFC		Chemical Parameters - TFC	
Community / Private	Bacteriologically Safe	Hardness (CaCO <sub>3</sub> )	< 170 mg/L (< 10 gpg)
System Pressure min/max	30 / 100 psi	Iron (Fe)	< 0.1 mg/L
Temperature	4° / 38°C (40° / 100° F)	Manganese (Mn)	< 0.05 mg/L
pH Range	3.0 to 11.0	Hydrogen Sulfide (H <sub>2</sub> S)	0.00 mg/L
Maximum supply TDS level	1800 mg/L	<b>Production Rate</b>	
Turbidity	< 1.0 net turbidity (NTU)	Daily Production Rate	13.4 gallons per day