

# 3M™ Water Filtration Products

SPEC# \_\_\_\_\_

QUANTITY \_\_\_\_\_



models:

## HF295-CL

3M™ Water Filtration Products Model HF295-CL water filtration system helps provide consistent high quality water for commercial foodservice applications by reducing the effects of sediment, chloramines, chlorine taste & odor at flow rates up to 5.0 gpm (18.9 lpm).

### PRODUCT BENEFITS

- Carbon block technology effectively reduces chloramines, chlorine taste & odor for better equipment protection and premium Recipe Quality Water™.
- NSF Standard 42 and FDA CFR-21 compliant materials.
- Sanitary Quick Change (SQC) encapsulated cartridge design allows for fast and easy cartridge change-outs with ¼" turn.
- 3/4" MNPT horizontal inlet and outlet ports allow direct or easily adaptable connections to existing plumbing lines.

### PRODUCT SPECIFICATIONS

Model Number	Part Number	Reduction Claims	Nominal Micron Rating	Capacity	Service Flow Rate	Replacement Cartridge
HF295-CL	56275-01	Sediment, Chloramines <sup>1</sup> , Chlorine Taste & Odor	5.0 <sup>2</sup>	60,000 gallons (227,100 liters)	5.0 gpm (18.9 lpm)	HF95-CL (Qty 2) (56273-02)

<sup>1</sup> As tested and certified by independent third party laboratory

<sup>2</sup> NSF Certified for Particulate Reduction



# HF295-CL

SPEC# \_\_\_\_\_  
 QUANTITY \_\_\_\_\_  
 MODEL NUMBER \_\_\_\_\_  
 PART NUMBER \_\_\_\_\_

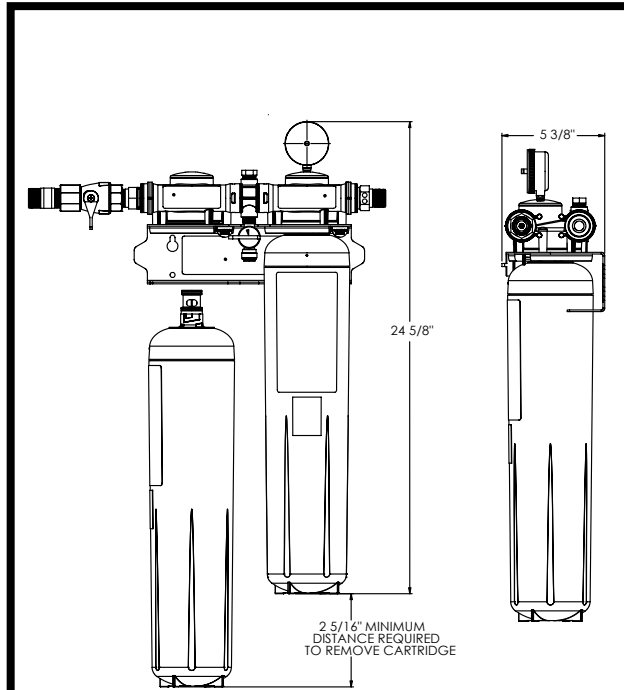

**⚠ WARNING: To reduce the risk associated with the ingestion of contaminants:**

- Do not use with water that is microbiologically unsafe or of unknown quality without adequate disinfection before or after the system.

3M Purification Inc. recommends regularly scheduled maintenance and replacement of the filter cartridge(s) in order for the product to perform as advertised/sold. 3M Purification Inc. shall not be liable for system failures due to improper maintenance.

## LIMITED WARRANTY

3M Purification Inc. warrants this Product will be free from defects in material and manufacture for five (5) years from the date of purchase: The filter cartridge or filter membrane is warranted to be free from defects in material and manufacture for one (1) year. This warranty does not cover failures resulting from abuse, misuse, alteration or damage not caused by 3M Purification Inc. or failure to follow installation and use instructions. No warranty is given as to the service life of any filter cartridge or membrane as it will vary with local water conditions and water consumption. **3M PURIFICATION INC. MAKES NO OTHER WARRANTIES OR CONDITIONS, EXPRESS OR IMPLIED, INCLUDING, BUT NOT LIMITED TO, ANY IMPLIED WARRANTY OR CONDITION OF MERCHANTABILITY OR FITNESS FOR A PARTICULAR PURPOSE OR ANY IMPLIED WARRANTY OR CONDITION ARISING OUT OF A COURSE OF DEALING, CUSTOMER OR USAGE OF TRADE.** If the Product fails to satisfy this Limited Warranty during the warranty period, 3M Purification Inc. will replace the Product or refund your Product purchase price. This warranty does not cover labor. **The remedy stated in this paragraph is Customer's sole remedy and 3M Purification Inc.'s exclusive obligation. For additional information, see the entire Limited Warranty located in the product Installation and Operating Instruction Manual.**

**Limitation of Liability.** 3M Purification Inc. will not be liable for any loss or damage arising from this 3M Purification Inc. product, whether direct, indirect, special, incidental, or consequential, regardless of the legal theory asserted, including warranty, contract, negligence or strict liability. Some states and countries do not allow the exclusion or limitation of incidental or consequential damages, so the above limitation or exclusion may not apply to you.

# 3M™ Water Filtration Products

## APPLICATION GUIDE

Post Mix	
Dual or Triple Carbonator Dispensers	12 Oz. Cups: 960,000* 16 Oz. Cups: 640,000* (*Assumes 4 Oz. volume of Ice)
Juice Machines	
Single and Multi-Dispenser, Push Button and Portion-Control Juice Machines	6 Oz. Cups: 1,280,000 12 Oz. Cups: 640,000
Ice Tea Brewers (Low Incoming Water Hardness)	
3, 3.5, and 4 Gallon Tea and Iced Tea Brewers	3 Gal. Dispensers: 20,000 3.5 Gal. Dispensers: 17,142 4 Gal. Dispensers: 15,000 5 Gal. Dispensers: 12,000 12 Oz. Cups: 640,000
High Volume Coffee with Low Incoming Water Hardness	
1, 2, and 3 Warmer Brewers, Liquid Coffee, Airpot Brewers and 3 Gallon Urns	1/2 Gal. Pots: 120,000 3 Gal. Urns: 20,000 12 Oz. Cups: 640,000 2.5 Liter Airpots: 90,840

## IMPORTANT: INSTALLATION TIPS

These installation tips are for informational purposes only and are not intended to be used as actual installation instructions. **CAUTION: To reduce the risk associated with property damage due to water leakage:**

- Read and follow Use Instructions before installation and use of this system.
- Installation and use **MUST** comply with all state and local plumbing codes.
- Protect from freezing**, remove filter cartridge when temperatures are expected to drop below 40°F (4.4°C).
- Do not install on hot water supply lines.** The maximum operating water temperature of this filter system is 100°F (37.8°C).
- Do not install** if water pressure exceeds 125 psi (862 kPa). If your water pressure exceeds 80 psi (552 kPa), you must install a pressure limiting valve. Contact a plumbing professional if you are uncertain how to check your water pressure.
- Do not install** where water hammer conditions may occur. If water hammer conditions exist you must install a water hammer arrester. Contact a plumbing professional if you are uncertain how to check for this condition.
- The disposable filter cartridge **MUST** be replaced every 12 months, at the rated capacity or sooner if a noticeable reduction in flow rate occurs.



3M Purification Inc.  
 400 Research Parkway  
 Meriden, CT 06450 U.S.A.  
 Toll Free: 1-866-990-9785  
 Worldwide: 203-237-5541  
 Fax: 203-238-8701  
 www.3mpurification.com  
 www.3mfoodservice.com

3M is a trademark of 3M Company.  
 NSF is a trademark of NSF International.  
 Recipe Quality Water is a trademark  
 of 3M Company used under license.  
 © 2013 3M Company. All rights reserved.  
 70020302082 REV 0813



Visit [www.nsf.org](http://www.nsf.org) for the claims associated with products that are NSF listed.